Note to the reader: The current version of the DCI Digital Cinema System Specification (DCSS) is *DCI Specification, Version 1.2 with Errata as of 30 August 2012 Incorporated* in combination with Errata 1-9. This is a draft document that shows the differences (additions and deletions) between chapters 7 and 9 of the previous DCI Specification, *Version 1.2 with Errata as of 30 August 2012 Incorporated*, and the current version of the DCSS noted above. The actual documents (not this “changes-marked” document) are the definitive expressions of their respective DCSS versions and prevail in the event any interpretation is required.

Approved for publication 4 September 2014, Digital Cinema Initiatives, LLC,
Member Representatives Committee.
Copyright © 2005-2014 Digital Cinema Initiatives, LLC

9. SECURITY

9.1. Introduction

This section defines the requirements for Digital Cinema security. Though security is an end-to-end process, these specifications are focused on the exhibition environment. *The high level business requirements for security are:*

- *Enable the decryption and playback of feature films, based upon business rules agreed upon by Exhibition and Distribution.*
- *Provide persistent security protection against unauthorized access, copying, editing, or playback of feature films.*
- *Provide records of security-related events.*

The high level technical requirements for security are:

- *Meet the above business requirements.*
- *Define an open security architecture.*
- *Provide a minimum set of standards around which the exhibition security infrastructure can be implemented by multiple equipment suppliers.*

Security is provided primarily through the application of encryption technology and the management of content key access. When content is transported and received in an encrypted fashion, it is necessary to establish standardized methods of delivering and utilizing decryption keys to unlock the content. This is known as key management. Associated with key exchange is DRM (Digital Rights Management), which establishes the rules for using content. The management of DRM is known as security management. *DRM requirements include logging of content access and other security event information.*

In the security architecture defined herein, security management functions are entrusted to a Security Manager (SM), a logically separable and functionally unique component of the architecture. The security system is referred to as the infrastructure that provides security features, and the Security Manager is at the heart of this infrastructure. ~~*At exhibition, each Digital Cinema auditorium shall have its own dedicated security system, which is comprised of multiple subsystems under the supervision of the Security Manager.*~~ The security system architecture is defined to provide open and standardized security

operation and enable interoperability between an exhibition SM and the rest of the exhibition security infrastructure.

This specification originally required that a single SM be assigned to an auditorium projection booth. The requirement for a single SM is eliminated. Multiple SM's per auditorium (each contained within a Media Block as further specified herein) is permitted by this specification, which enables Multiple Media Block (MMB) auditorium equipment configurations.

Section 9 SECURITY is organized as follows:

- **Fundamental Security Requirements** (Section 9.2)– System-level goals, which security implementations are required to meet.
- **Security Architecture Overview** (Section 9.3)– Definitions and description of the basic security architecture, security messaging, and role of the Security Manager.
- **Theater Systems Security** (Section 9.4)– Security and equipment functions, behavior requirements and security operations at exhibition.
- **Implementation Requirements** (Section 9.5)– Requirements for equipment implementation, physical and logical robustness and certification.
- **Security Features and Trust Management** (Section 9.6) – The requirements and implementation of security policy and trust infrastructures.
- **Essence Encryption and Cryptography** (Section 9.7)– Cryptographic requirements for essence encryption and related cryptography.
- **Digital Certificates, Extra-Theater Message and Key Delivery Message Requirements** (Section 9.8.) – Detailed requirements for Digital Certificates, Extra-Theater Message and Key Delivery Message.

The following acronyms are introduced and used extensively in Section 9

SM	Security Manager
KDM	Key Delivery Message
ETM	Extra-Theater Message
ITM	Intra-Theater Message
TDL	Trusted Device List
FM	Forensic Marking (Marker)
SE	Security Entity
SPB	Secure Processing Block
RRP	Request-Response Pairs

9.2. Fundamental Security System Requirements

This section describes the goals for the security system. Cryptographic security requires communications connectivity between Distribution and Exhibition, above what is required for 35mm film. However, at no time do security requirements mandate continuous on-line connectivity to an exhibition facility.

Note: Due to the dynamic nature of security technology, DCI reserves the right, at some future time, to update requirements and may require changes to Digital Cinema systems as situations warrant.

9.2.1. Content Protection and Piracy Prevention

The security system shall provide a means for the securing of content against unauthorized access, copying, editing, and playback. Protection shall be standardized primarily through the application of encryption technology, management of content key access and robust logging.

9.2.2. Single Inventory and Interoperability

The security system shall support a single inventory Digital Cinema Package (DCP) delivered to every compliant theater installation. The security system architecture shall support file interoperability for both the Digital Cinema Package (DCP) and the Key Delivery Message (KDM). The security system architecture shall require system interoperability between Security Manager (SM) and Screen Management System (SMS).

9.2.3. Reliability

The security system shall recognize that “the show must go on” except in extreme circumstances. The model shall support intelligent means to locate failures expeditiously, and support field replaceable security devices.

9.2.4. Support Forensics and Attack Detection

- *The security system shall produce records of the access to secured content at authorized facilities.*
- *The security system shall support techniques to expose security attacks in process prior to an actual loss.*
- *The security system shall support techniques (e.g., Forensic Marking) to implant evidence of origin of the content for use in tracing unauthorized copies of the content to the source.*
- *The security system shall support the interface(s) and operation of anti-camcorder devices. This may include, but is not limited to, the ability to log the results of an anti-camcorder (detection of a camcorder event) or a non-functional anti-camcorder-ing system.*

9.2.5. Resist Threats

The security system shall support prevention and detection of the following threats:

- *Content theft (piracy) – as noted above*
- *Unauthorized exhibition (e.g., at wrong facility)*
- *Manipulation of content (e.g., editing)*
- *Un-logged usage of content*
- *Denial of Service*

9.3. Security Architecture Overview

This section describes the architectural elements and fundamental operation of the Digital Cinema security system.

9.3.1. Definitions

- **Content** – The digital representation of a visual, audio or subtitled program. Content exists in several forms (encrypted/plaintext, compressed/uncompressed, etc) at various stages of the process in the Digital Cinema system.
- **Digital Cinema Package (DCP)** – The standardized form of content intended for delivery to theatrical exhibition facilities. DCP content components are selectively encrypted by the Rights Owner.
- **Equipment Suite** ~~(Suite)~~ – ~~The~~A set of one or more Secure Processing Blocks associated with security devices (including one Security Manager) that collectively support essence playback through a projector auditorium. For example, an IMB and a projector (with or without Link Encryption) comprise a suite. A stand-alone Outboard Media Block (“OMB”, see below) is not connected to a projector and is not part of an Equipment Suite.
- **Extra-Theater Message (ETM)** – One-way information packet that passes into or out of, the exhibition facility. The ETM is a generic message container.
- **Forensic Mark** – The generic term used in this specification for any or all of the following: watermarking, fingerprinting, and/or forensic watermarking functions used at the time of playback.
- **Intra-Theater Message (ITM)** – The data packet that passes between Secure Processing Blocks ~~security devices~~ assigned to a single Equipment Suite ~~auditorium~~. ITM(s) operate on two-way channels.
- **Key Delivery Message (KDM)** – The Extra Theater Message (ETM) for delivering content keys and Trusted Device List (TDL) to exhibition locations.
- **Log Data** – The data produced and stored as a result of security system activity.
- **Media Block (MB)** – A type of Secure Processing Block ~~security device~~ that contains a Security Manager and performs media decryption. This specification defines the Image Media Block (IMB) and the Outboard Media Block (OMB).
- **Multiple Media Block (MMB)** – Refers to a projection booth configuration containing more than one Media Block.
- **Rights Owner** – The generic term used to describe the party having authority over content to negotiate terms of engagements (e.g., a studio or distributor).
- **Screen Management System (SMS)** – A (non-secure) Security Entity (SE) that directs security functions for a single auditorium on behalf of exhibition management.
- **Secure Processing Block (SPB)** – A Security Entity (SE) which provides a physical and logical protection perimeter around other SEs.
- **Security Data** – The keys and associated parameters required for access to content, and managed by Security Managers.
- **Security Entity (SE)** – A logical processing device which executes a distinct security process or function. SEs are not distinguished from other theater equipment by being physically secure, but by the specific security function that they perform (see Section 9.3.3 Security Messaging and Security Entities).
- **Security Interface** – A standardized point of interoperability for security messaging.

- **Security Management** – The process of securely distributing, storing and utilizing Security Data in order to access content.
- **Security Manager (SM)** – ~~A *conceptual device* Security Entity (SE) that *is entrusted to controls* Security Data according to a defined policy. *There shall be one SM within each MB. Wherever this term is used, it shall be understood that an SM is installed in each auditorium, and each reference is to an auditorium SM.*~~
- **Stakeholder** – A party involved in a business agreement relating to distribution and exhibition of specific Content.
- **Trusted Device List (TDL)** – A list of specified security devices which are approved to participate in playback of a particular composition at the exhibition facility.

9.3.2. Security Management Approach to Security

The security architecture described herein distinguishes security management from content management. Once content is encrypted, it is “purpose neutral and safe” and can be allowed to take any path desired at any time to any destination. Thus, content management (physical distribution) can be implemented along lines that are oriented towards business needs, commercial cost effectiveness, and convenience. “Purpose neutral and safe” means once content is encrypted, its purpose has been neutralized (as to the content type, information contained, etc.) and it is safe (one does not care where it goes, how it gets there or who has access to it).

Access to encrypted content is controlled by the security management function. That is, content access is enabled or denied through control of Security Data. This function is entrusted to a Security Manager (SM), a logically separable and functionally unique component of the architecture. At exhibition, the SM controls Security Data, and consequently, access to content.

~~In the theater, Digital Cinema systems will have an SM assigned to each auditorium/projector. At the theater, access to content is provided via one or more Media Blocks (MB), each containing an SM.~~ For each playback, each SM will require, and be delivered, one or more unique keys to unlock encrypted content files. All distributors will share the ~~is~~ SM(s).

Each key is delivered in a Key Delivery Message (KDM) with a specified play period. That is defined as the time window when the key is authorized to unlock the content. There is a start time/date and a stop time/date associated with each key. The authorized window for each key will be part of the normal engagement negotiation between Exhibition and Distribution. ~~The Security Manager will authenticate the identity and integrity of the auditorium security equipment for each showing, and thereafter enable the use of the appropriate keys during the authorized play window.~~

9.3.3. Security Messaging and Security Entities

The security system described herein implements a standardized open architecture in which equipment used at exhibition facilities can be sourced from multiple, competing suppliers. In order to achieve interoperable security operation, the security system design for Exhibition, specifies a standard message set for interoperable communications between standardized security devices.

9.3.3.1. Security Messages

There are two classes of messages in the architecture:

- **Extra-theater Messages (ETM)** – These are self-contained one-way messages that move Security Data and information outside or within the theater. These specifications have defined a fundamental message structure for a generic ETM, the requirements for which are normative and given in Section 9.8
- **Intra-theater Message (ITM)** – Messages that move security information within the auditorium over a real-time two-way channel. Requirements for the ITM infrastructure are given in Section 9.4.5 Intra-Theater Communications.

Figure 14: shows typical locations of SM functions¹, ETM² and ITM message interfaces. ETM message types are labeled with a black 1 and ITM messages with a red 2.

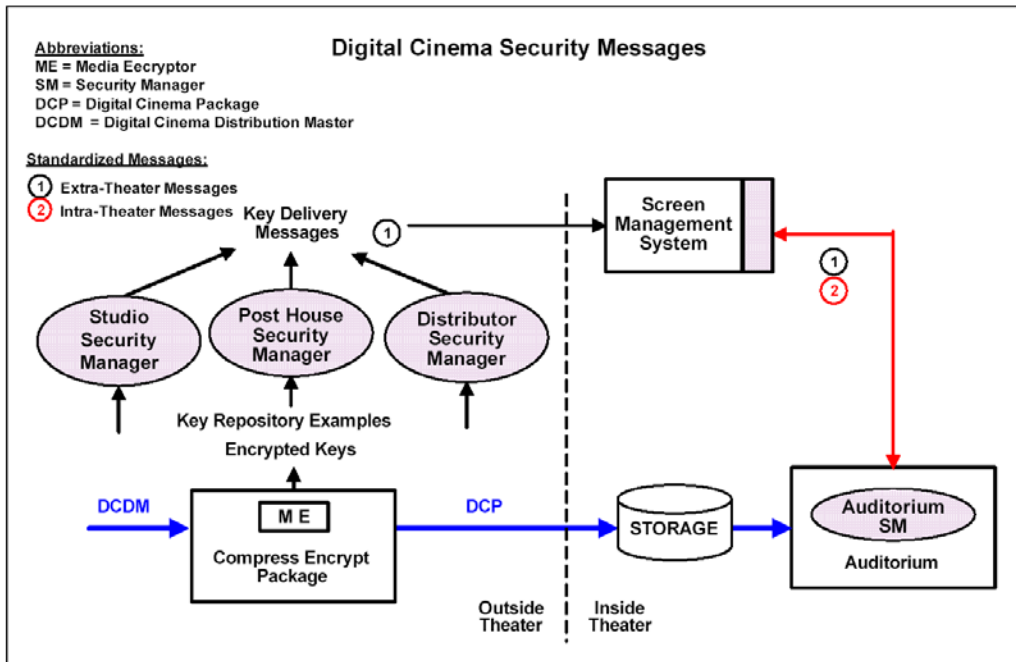

Figure 14: Digital Cinema Security Message Flow

9.3.3.2. Security Entities

Security Entities (SE) are characterized by executing in a narrowly defined security function, and having a role defined for them in a digital certificate with which they are associated. *The seven defined SE(s) are as follows (these are developed more fully in Section 9.4 Theater Systems Security).*

1. *Screen Management System (SMS) – The SMS is not a secure device and therefore is not trusted to handle Security Data (keys). The SMS is trusted to send/receive commands*

¹ There may be various types of SM functions. These specifications are focused on the auditorium SM and its security management roles. SM functional and behavioral requirements are specified in Section 9.4.3 Theater Systems Security Operations

² The KDM is a type of ETM, and its creation location may vary. The KDM is normatively specified in Section 18.8

to/from the auditorium SM, such as those required to prepare an equipment suite for playback.

2. *Security Manager (SM) – Responsible for Security Data (keys) and Digital Rights Management within a defined sphere of control (see Section 9.6.2 “Trust” and the Trusted Device List (TDL))*
3. *Media Decryptor (MD) – Transforms encrypted (image, sound, etc.) content to its original plaintext form*
4. *Link Encryptor (LE) – Encrypts content transmission over links between physical devices in exhibition*
5. *Link Decryptor (LD) – Decrypts content encrypted by a Link Encryptor (LE)*
6. *Forensic Marker (FM) – Inserts markings (data indicating time, date and location of playback) in both image and audio essence in realtime at time of playback (i.e., a fingerprint or watermark inserter)*
7. *Secure Processing Block (SPB) – A Security Entity (SE) whose security function is to provide physical protection to other SEs contained within it. A Media Block is an example of a SPB. These specifications define two types of SPB physical protection perimeters (see Section: 9.4.2.2 The Secure Processing Block (SPB)).*

Security Entity Notes:

- *The term Security Entity should not be confused with secure entity. The term secure entity is not normatively defined or used in these specifications, as the SPB function serves this purpose, and is normatively defined.*
- *The Link Encryptor and Link Decryptor Security Entities exist only when Link Encryption is used.*
- *The SMS is not a secure device, and is sometimes viewed as part of the media server, or as part of the TMS. These security specifications focus on the SMS as the auditorium controlling device, independently of its scope or totality of other functions it may provide (see Section: 9.4.2.5 Screen Management System (SMS)).*

9.4. Theater Systems Security

9.4.1. Theater System Security Architecture

The Theater System is comprised of those components, at an Exhibition location, that are required by the security system to support playback of a show. Once in possession of the complete DCP and its associated KDMs, the theater security system can independently enable playback of the composition.

Theater System Security requirements are:

1. *Each auditorium shall have one or more Image Media Blocks (IMB), each associated with one projector. Each auditorium may have Outboard Media Block(s) (OMB) as further defined herein. ~~authenticating Media Block, containing an auditorium SM that Rights Owners will share. The authenticating MB shall be the Image Media Block (IMB).~~*
2. *The ~~auditorium~~ IMB SM shall have knowledge of the projector it enables, by being able to authenticate that the projector has been certified to meet content protection requirements.*

Authentication shall be assured via a projector certificate, which shall be associated with the projector's SPB type 2 (see Section 9.5.1 Digital Certificates and Section 9.5.2 Robustness and Physical Implementations).

3. The Every IMB shall include image, audio and subtitle decryption capability. An OMB shall decrypt only the content essence types designated by this specification (see Section 9.4.3.6.4 Normative Requirements: Outboard Media Block).
4. The Every IMB shall include image and audio Forensic Marking (FM) capability. The OMB may include FM for the content essence it decrypts, as defined by the requirements of the OMB normative requirements Section 9.4.3.6.4.
5. If Link Encryption (LE) exists, the Link Decryptor (LD) Block shall be authenticated to the IMB SM. ~~Forensic Marking within an LD Block shall be optional.~~
6. All Image-Media Blocks and Link Decryptor Blocks shall be of the SPB type 1 (see Section 9.4.2.2. The Secure Processing Block (SPB)), and shall be field replaceable, but non-field serviceable.³
7. Secure Processing Block (SPB) devices (and the SEs contained within them) shall have normative security and operational behavior requirements specified. Security Managers shall monitor the functioning of all SPB/SE devices and invoke controls to prevent use of improperly operating security equipment. To the extent possible, all security devices shall be designed with self-test capability to announce and log failures and take themselves out of service.

Figure 15 presents the two fundamental auditorium security system architectures, with and without Link Encryption, and the security message types ETM and ITM. This diagram does not attempt to detail functions that are unrelated to security (e.g., decoding), but does anticipate such functions by noting where plain text content exists.

Though not shown in Figure 15: Digital Cinema Auditorium Security Implementations, but as indicated in the requirements above, every auditorium shall support image, audio, and subtitle decryption⁴, and image and audio Forensic Marking.

This specification also includes requirements for projection booth operation with equipment configurations beyond those shown in Figure 15 as follows:

- ~~Additionally, for so-called "Special Auditorium Situations --,"~~ An auditorium Equipment Suite may enable the use of more than one projection system associated ~~with~~ a single Image Media Block (IMB)screen in a given auditorium, multiple Link Encryption stages and/or an LD/LE SPB image processing device (see Section 9.4.4.1 "Special Auditorium Situations").

³ "Non-field serviceable" means not serviceable by other than the equipment vendor or his authorized and supervised service repair depot (see Section 9.5.2.3 Repair and Renewal)

⁴ Subtitle encryption is directed primarily against interception during transport, and cryptographic protection within the theater is not required. For example, plaintext subtitle content may be transmitted from a server device to a projection unit. It is preferred, but not required, that subtitle content be maintained in encrypted form except during playback.

- Multiple Media Block (MMB) – Refers to the use of the IMB and one or more Outboard Media Blocks (OMB) to support playout. This enables flexibility to provide media processing beyond that specified for the IMB. Additionally, MMB provides requirements for multiple IMB operation to support multiple projectors (i.e., as alternative to the above Special Auditorium Situation).

The Special Auditorium Situation expands the utility of a single IMB to support multiple projectors, while MMB expands the use of Media Blocks (MB). An important point is that with MMB each MB (IMB(s) and/or OMB(s)) contains a Security Manager (SM) and Security Entities (SE) which process Digital Cinema Package (DCP) media essence simultaneously with, but independently of, other MBs during playout within a single auditorium. In addition to the appropriate DCP content essence, each MB must be supplied with the Composition Playlist(s) (CPL) and matching KDM(s) to support the entire show (which may consist of multiple compositions). MMB operational requirements are described in Section 9.4.3 Theater Security Operations.

9.4.1.1. Architecture Description and Comments

The security architecture descriptions and requirements revolve around two embodiments: the SPB and the SE. As defined in Section 9.3.3 Security Messaging and Security Entities, SEs are logical devices that perform specific security functions. They are logical because these specifications do not dictate how SEs are actually designed, and more than one type of SE may be implemented within a single circuit.

All functional Security Entities (SEs) (except the SMS) shall be contained within SPBs, which provide physical protection for the Security Entities (SEs). The SPB is itself a literal SE Type – its security function is physical protection. The Security Entities (SEs) and SPB type 1 and type 2 containers are depicted in Figure 15: Digital Cinema Auditorium Security Implementations. This figure shows that there shall be only three permitted physical protection scenarios:

- *No physical protection required – Screen Management System (SMS)*
- *SPB type 1 protection required – Image Media Block (IMB), Outboard Media Block (OMB), Link Decryptor Block (LDB) and LD/LE SPB Devices*
- *SPB type 2 protection required – Content essence entering the projector from an IMB or LD Block*

These requirements are more fully defined in the SM and SPB functional requirements below (see Section 9.5 Implementation Requirements).

Note: The security network is shown (in red) in Figure 15: Digital Cinema Auditorium Security Implementations. This is described below as operating under Transport Layer Security (TLS), a readily available and well known protocol standard for providing protection between application layer processes that must communicate between devices, in this case between **auditorium devices** (Secure Processing Blocks (SPB) performing security functions).⁵

⁵ Transport Layer Security (TLS) can be viewed as an extension of the SPB physical protection container, but for communications, a “steel pipe” that surrounds the wire between devices. Thus, these specifications define both physical and logical protection mechanisms for all security and playback processes.

As part of TLS session establishment, each party to the session presents its digital certificate to the other. In this fashion, the IMB Security Manager identifies the other SPBs in the auditorium, and mutual authentication is accomplished (see Section 9.4.3.1 Transport Layer Security (TLS) Establishment and Secure Processing Block (SPB) Authentication and Section 9.4.5.1 Transport Layer Security Sessions, End Points and Intra-Theater Messaging). Although the SM may establish secure TLS communications with an SPB, it will not “trust” (approve) that SPB for content playback functions until the identity of such SPB appears on the appropriate Trusted Device List (TDL) for the particular composition (see Section 9.6.2 “Trust” and the Trusted Device List (TDL)).

The playback processes begins and ends with the SMS, under the control of Exhibition. Thus, the SMS is viewed as the initiator of security functions, and the window into the exhibition security system. Protection over cryptographic processes begins by requiring the SMS to communicate, in a secure fashion (i.e., under TLS), with the Security Managers (SM) under its control. The security system takes advantage of these secure command and control features to protect itself, as well as the exhibition operator, from several forms of attacks, including SMS imposters and Denial of Service.

While it is true that the security system places no physical protection requirements on the SMS, the extent to which the SMS is vulnerable to being tampered with, or its functions subverted, is a result of exhibition implementation and policy (e.g., who gets access to the SMS, how it is physically protected by room locks, operator access). The security system requires the SMS and SMS operator to identify itself to the Security Manager. The extent to which this information is reliable is subject to issues outside the scope of the security system and this specification. But the security system structure and standards requirements are appropriately specified to enable policies to regiment these aspects according to any particular security needs, without needing to change or enhance SE device operations or features.

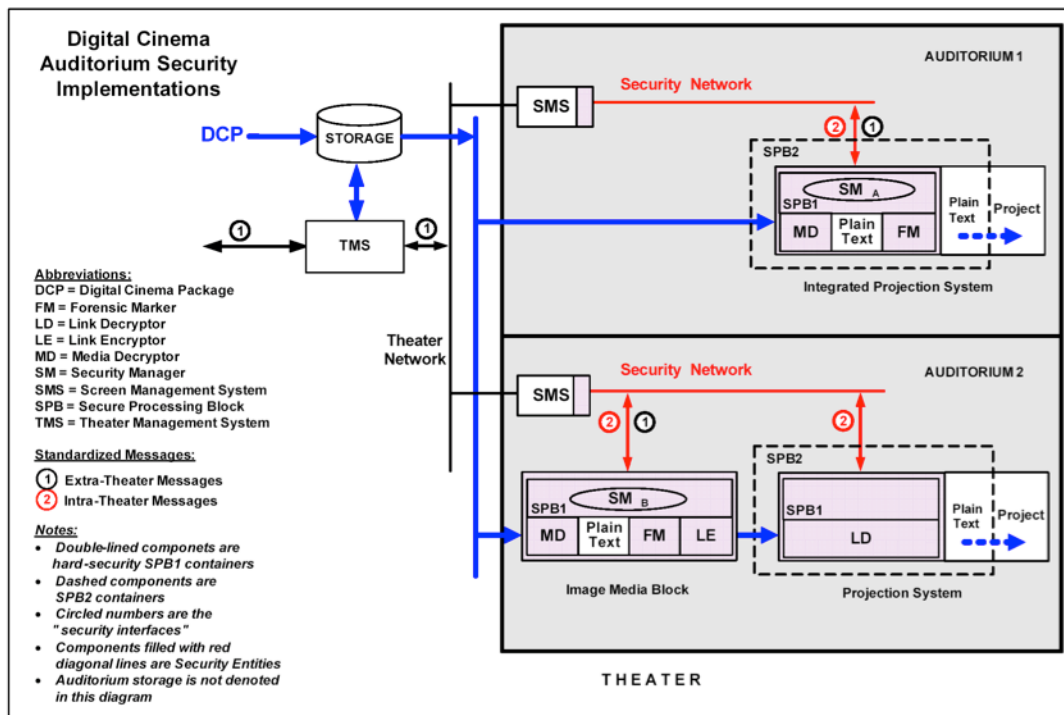

Figure 15: Digital Cinema Auditorium Security Implementations

Note to the reader: Figure 15 has been updated as follows: Two edits for "AUDITORIUM 2": Removed (1) the asterisk from "FM" (in the projection system) and (2) the associated " *optional " word. the "FM" box from the projection system block in auditorium 2. The entire lower half of SPB2 in auditorium 2 eliminates "FM" and "Plain Text", and shows only "LD". The partitions have been removed, making the lower half one long box that says "LD".

9.4.2. Theater System Security Devices

Although SEs are not distinctly visible outside of the SPB that contains them, SEs exist logically, and their normative behavior is specified in conjunction with the requirements defined below for SPB systems (see Section 9.4.3.5 Functions of the Security Manager (SM) and Section 9.4.3.6 Functional Requirements for Secure Processing Block Systems). This is accomplished using a traditional Applications Programming Interface (API) approach, where the focus of the interoperability point is the SPB (logical) interface, and associated messaging and operational behavior at the interface.

9.4.2.1. Equipment Suites

Several SPBs may be grouped to support an auditorium. Security requirements ~~do not define an auditorium per se, but instead~~ refer to thea collection of equipment in athe display chain under control of one IMB SM that supports a projector as an Equipment Suite. An Equipment Suite minimally consists of an IMB and projector, but may additionally include, for example, LDB and/or LD/LE SPB types. The key characteristic of an Equipment Suite is that the IMB SM is responsible for authenticating other SPBs comprising the suite. (The stand alone Outboard MB

~~(OMB) does not support a projector or authenticate other SPBs, and is thus not part of a suite.)
A playback of a show will be associated with an equipment suite, and that suite must be set up
(prepared) by the requisite IMB SM ahead of the show for each playback (see Section 9.4.3.6.3
Normative Requirements: Image Media Block (IMB)) This takes place for each showing by
command of the SMS.~~

The installation and configuration of equipment that comprises suites is an exhibition management function.

9.4.2.2. The Secure Processing Block (SPB)

The SPB is defined as a container that has a specified physical perimeter, within which one or more SE and/or other plaintext processing functions are placed (e.g., decryptor, decoder, Forensic Marker). The SPB exists to enclose SEs and other devices in the content path, impede attacks on those SEs, and to protect signal paths between the SEs.

There are two normatively defined SPB types:

- **Secure Processing Block type 1** – An SPB type 1 provides the highest level of physical and logical protection. *Image Media Blocks and Link Decryptor Blocks shall be contained within a type 1 SPB.* (These are shown as double-lined boxes filled with diagonal lines in Figure 15: Digital Cinema Auditorium Security Implementations). *Additionally (and not shown in Figure 15) the Outboard Media Block (OMB) and LD/LE SPB Devices shall be contained within a type 1 SPB.*
- **Secure Processing Block type 2** – An SPB type 2 provides a lesser perimeter of protection, for content or security information that does not require the full SPB type 1 protection. *SPB type 2 protection shall be provided by projectors as shown as the dotted line around the SPB type 1 devices as shown in Figure 15⁶.*

Secure Processing Blocks (SPBs) shall provide a hard, opaque physical security perimeter that meets minimum security requirements as defined in 9.5.2 Robustness and Physical Implementations. Both SPB types are considered a Security Entity (SE), and shall be assigned a digital certificate per Section 9.5.1 Digital Certificates

9.4.2.3. Media Blocks (MBs)

The term Media Block⁶ (MB) has been used by the Digital Cinema industry in a number of ways. In this Section 9 SECURITY, it has a very narrow scope: An MB is an SPB that contains a Security Manager (SM) and performs essence decryption, i.e., it contains at least one MD. *Other SE functions may also be present within a MB SPB, as described below:*

- **Image Media Block (IMB)** – *The Image Media Block (IMB) is a type 1 of Secure Processing Block (SPB) that shall contain a Security Manager (SM), Image, Audio and Subtitle Media*

⁶ In Section 7 THEATER SYSTEMS Media Blocks are also discussed. The terminology used there is not strictly security focused, because other important equipment requirements such as storage and server functions are discussed. Depending upon a particular design, server functions may well be part of what is in a MB, when viewed in its entirety. Since other such functions are invisible to security, they need not be discussed within the security arena, and are not addressed in this security chapter.

Decryptors (MD), image decoder, Image and Audio Forensic Marking (FM) and optionally Link Encryptor (LE) functions. It is encouraged for the IMB to optionally contain the content essence processing to perform the functions of the Outboard Media Block (OMB). The IMB SM is responsible for security for a single Equipment Suite~~auditorium~~, and it authenticates other SPBs that comprise the suite~~are required to participate in showings~~. Other such SPBs are referred to as remote ~~or external~~ SPBs.

- **Outboard~~Remote~~ Media Block (OMB)** – The OMB is a type 1 SPB that shall contain a Security Manager (SM) and one or more Media Decryptors (MD) and associated Forensic Markers (FM) to process (only) those content essence types explicitly designated in Section 9.4.3.6.4 “Outboard Media Block (OMB)”. ~~A remote Media Block is a remote SPB that contains other types of MDs, such as those used for audio or subtitles, but does not contain an SM. Remote Media Blocks shall not be used in DCI-compliant systems.~~

9.4.2.4. Security Manager (SM)

The SM controls Security Data and content access in a manner consistent with the policies agreed upon by the Stakeholders who rely upon it. There is one SM for each Media Block~~auditorium~~, and ~~it shall be contained within the IMB.~~ The Rights Owners (Distribution) shall share the is SM(s) for their security needs.

Security Manager functions shall conform to the requirements as given in Section 9.4.3.5 Functions of the Security Manager (SM) and Section 9.6.1 Digital Rights Management. The Security Manager is a self-contained system with an embedded processor and real-time operating system. SM functions shall not be implemented outside of the secure environment of the Image Media Block (IMB) or Outboard Media Block (OMB) SPB.

The Security Manager is a self-contained processor running a real-time operating system. *The operating environment shall be limited to the FIPS 140-2 limited operational environment category (Section 9.5.2.5 FIPS 140-2 Requirements for Type 1 Secure Processing Blocks), meaning that the SM’s operation shall not be modifiable in the field. The only security communication with systems (processors) external to the SM’s SPB shall be by Transport Layer Security (TLS) over a network interface per Section 9.4.5.1 Transport Layer Security Sessions, End Points and Intra-Theater Messaging.* The preferred real time operating system would use the National Security Agency (NSA) kernel and would be specifically designed for secure operations.. *The Security Manager software shall use all appropriate security features of the operating system.*

Security Manager software changes and upgrade requirements are given in Section 9.5.2.7 SPB Firmware Modifications.

9.4.2.5. Screen Management System (SMS)

Theater management controls auditorium security operations through the Screen Management System (SMS). *Because the SMS interacts and communicates directly with the security system, per Section 9.3.3.2 item 1, it is also considered to be a Security Entity (SE).* The SM responds to the directives that Theater Management System (TMS) issues via the SMS. For purposes of simplicity, and subject to the TMS constraint below, this specification uses the term SMS to mean either/both Theater Management System (TMS) or Screen Management System (SMS).

From the security system perspective, SMS functions are those associated with “category 1” Intra-Theater Messages of Table 15: Intra-theater Message (ITM) Request-Response Pairs (RRP).

SMS Requirements:

- *The SMS shall carry a DCI compliant digital certificate (see Section 9.5.1) to identify the SMS entity to the SM. The SMS certificate shall indicate only the SMS role unless the SMS is contained within a SPB meeting the protection requirements for any other designated roles.*
- *The SMS digital certificate may be permanent to the SMS, or “operator certificates” may be assigned to designated personnel (e.g., using a dongle, smart card, etc.) for association with the SMS.*
- *In the event that Exhibition command and control designs include the TMS as a device that interfaces with the SMSs, such a TMS shall be viewed by the security system as an SMS, and it shall carry a digital certificate and follow all other SMS behavior, Transport Layer Security (TLS) and Intra-Theater Message (ITM) communications requirements.*
- *Identification of the SMS operator for purposes of the “AuthorityID” field (see Section 9.4.5.2.4) shall be by:*
 - *Certificate thumbprint, where “operator certificates” are used, or*
 - *Username/password or the like, as specified by exhibition management.*

SM interaction with the SMS⁷ is normatively defined (see Section 9.4.3.5 Functions of the Security Manager (SM)). *These include the requirements that:*

- *The SM provides log records identifying the SMS for which it operates, as well as the AuthorityID field. In the case where “operator certificates” are used, this information is the same (i.e., the digital certificate thumbprint).*
- *If multiple SMSs are present, exhibition shall designate one to TLS connect with, and be used for identity logging by, all SMSs participating in any given showing. Upon request, this SMS shall be responsible for collecting and aggregating all post-show log data from all participating SMSs.*

9.4.2.6. Projection Systems

From the security perspective, a projection system consists of the projector type 2 Secure Processing Block (SPB) and its “companion” SPB, which will be either the Link Decryptor Block (LDB) or Image Media Block (IMB). A critical security issue is assuring that the clear text image output of the LDB or IMB goes to a legitimate projection device.

Therefore Section 9.4.3.6.1 Normative Requirements: Projector Secure Processing Block defines a “marriage” process with the companion SPB. The marriage, in conjunction with the Trusted

⁷ SMS-to-SM Intra-Theater Message (ITM) commands (see Section 9.4.5.3.1 Screen Management System to Security Manager Messages) include means to carry SMS operator identification via the “AuthorityID” field. The specific operational policies used at exhibition that surround operator identification, empowerment or enforcement are outside the scope of this specification.

Device List (TDL) and TLS-based authentication of the companion and projector SPBs, addresses the legitimate projector security issue.

The purpose of the marriage is to have a human authority figure supervise the installation of a projection system to assure the physical connection of the two SPBs, which TLS-based authentication alone cannot do. At the time of installation the authority figure can provide visual inspection of the projector to assure it has not been tampered with.

Once a projector is installed, the state of marriage is permanent (and monitored) until the authority figure decides to separate the two SPBs (for whatever reason). In addition, this specification establishes logging requirements surrounding projector installation and maintenance functions that record security-critical event information.

It is mandatory that a projection system installation includes the marriage function per Section 9.4.3.6 Functional Requirements for Secure Processing Block Systems (noting the permanently married exception provided for in that section). The marriage process shall require the supervision of a human authority figure, who shall examine projectors as part of the marriage process to assure the associated SPB has not been tampered with.

9.4.3. Theater Security Operations

This section describes how equipment conforming to the security system is used in normal theater operations. The show, expressed in a Show Playlist, consists of exhibition-arranged sequences of compositions, each of which is expressed by a Composition Playlist (CPL), any of which may be encrypted. One or more Rights Owners may supply Key Delivery Message(s) (KDMs) to provide all the content keys required for the Show Playlist.

With respect to security, theater operations break down into four categories:

1. Secure communications establishment and Secure Processing Block (SPB) device authentication
2. Pre-show preparations
3. Playback
4. Post playback

The SMS is generally responsible for initiating activity within each category, except the last, which is managed by the Security Manager (SM). The four scenarios are described and flow charted below for the single SM (one IMB and projector) and Multiple Media Block (MMB) configurations. For MMB situations multiple SMs are present, requiring the SMS to perform the described functions with each SM independently.

MMB operation provides for expanded auditorium configuration flexibility. It supports:

1. Multiple projectors – Multiple IMBs may be used, one for each projector (operation with or without Link Encryption (LE) follows all normal LE requirements of this specification).
2. Outboard Media Blocks (OMB) – One or more OMBs may be present to enable processing of DCP essence types beyond those processed by the IMB.

MMB is operationally supported as follows:

- Each participating MB/SM shall be provided with the CPL and a KDM for each composition of the Show Playlist (SPL). Each KDM shall be created (encrypted) uniquely for the MB/SM it is targeted for, and each KDM shall carry all the CPL identified essence keys required for the composition.
- Each MB/SM shall be provided with the appropriate DCP track files for the media essence to be processed by the respective MB. (This could be the entire DCP or portions of it according to where DCP track file parsing takes place.)
- The collective functionality of the Media Blocks within the projection booth to be used for any given DCP will be driven by the essence types in the DCP (for example, some DCPs won't use an OMB).

MMB functionality requires the collection of MBs to playback the image, audio and other time-dependent content in a manner that presents a synchronized performance to the audience. The requirements for synchronization are defined in Section 7.5.4.2.1 "Synchronization."

The above summaries are driven generally by a) the decisions of exhibition as to what the mixture of equipment is for their projection booths, b) the intentions of content creators with respect to DCP p layout, and c) the engagement agreements between these parties.

9.4.3.1. Transport Layer Security (TLS) Establishment and Secure Processing Block (SPB) Authentication

Exhibition has the liberty to power their equipment up and down as desired. *However, the Security Managers (SM) must ~~authenticate the equipment within their respective suites, and establish secure Transport Layer Security (TLS) sessions with the SMS and each remote SPB, and authenticate the equipment within its Equipment Suite (if applicable) with each power-on.~~ As previously described, the SM communicates securely with the SMS via TLS and records (logs) the SMS identity, but does not require SMS authentication. Authentication is required, however of the Equipment Suite SPBs, as described below.*

Note that the establishment of each TLS session enables the SM to authenticate the other party (~~remote SPBs or SMS~~) to the session and provides for secure ITM communications within the ~~Equipment Suite~~ auditorium. The SM does not "trust" such party for security functions related to content playback, unless the identity of the party appears on the Trusted Device List (TDL) delivered in the Key Delivery Message (KDM) for that particular Composition Playlist (CPL) (see Section 9.4.3.5 Functions of the Security Manager (SM) and Section 9.8 Digital Certificate, Extra-Theater Messages (ETM), and Key Delivery Messages (KDM) Requirements). Thus, device authentication and secure communications occurs independently of "trust"; the former being an exhibition equipment/infrastructure security issue, the latter being specific to a Rights Owner and a composition. Where content is not encrypted and no KDM/TDL exists, the SM does not invoke trust control.

The flow chart in Figure 16: System Start-Up Overview, is an example of how a system start-up may occur. This flow chart is informative. There are other designs that may have different steps or different sequences that will accomplish the same result and meet the requirements of this specification.

System Start-Up Overview

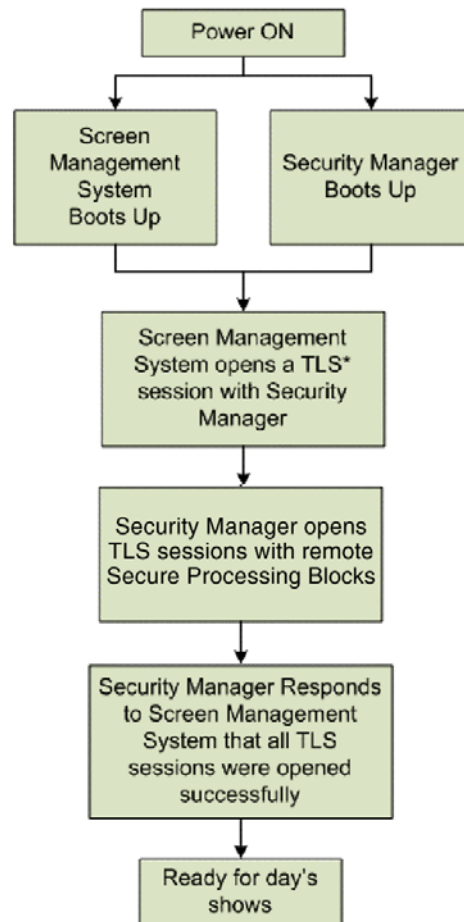

*TLS = Transport Layer Security

Figure 16: System Start-Up Overview

9.4.3.2. Pre-show Preparations

Pre-show preparations include tasks to be performed (well) in advance of show time to ensure adequate lead-time to resolve any issues that might impact the composition showing. These preparations do not prepare an auditorium for a showing, but are designed to provide assurance that all prerequisites for a specific showing have been satisfied.

- **Composition Playlist (CPL) and Key Delivery Message (KDM) check(s)** – *Composition Playlists (CPL) and Key Delivery Messages (KDM) shall be validated by the Security Manager(s) participating in the respective composition playback.*
- **Composition decryption preparations** – *Each encrypted composition will have associated with it one or more Key Delivery Messages (KDM), carrying time window constraints, decryption keys, and (as applicable) a Trusted Device List (TDL) to authenticate remote SPBs. The SMS, working with the security infrastructure, shall verify that all the KDMs and contained content keys required for playback are available and valid for scheduled exhibitions, and the suite equipment to be used for playback is on the associated TDL.*

- **Show playback preparations** – Exhibitors will assemble Show Playlists specific to each exhibition event, containing various compositions (including advertising, trailers, movies, etc.). *Because the final Show Playlists may involve many content keys and/or consist of content from different Rights Owners, it is the responsibility of the SMS to confirm that show preparations ~~should~~ ensure the auditorium SM(s) ~~has~~ confirmed possession of all necessary Key Delivery Message(s) (KDMs) for each composition of the Show Playlist. ~~In addition, FM devices may require configuration (keying) by the SM.~~*

The flow chart in Figure 17: Pre-Show Overview, is an example of how a system may prepare to execute a Show Playlist. This flow chart is informative. There are other designs that may have different steps or different sequences that will accomplish the same result and meet the requirements of this specification.

Pre-Show Overview

Note: While not a security function, it is assumed that the Exhibitor has created a Show Playlist for each auditorium

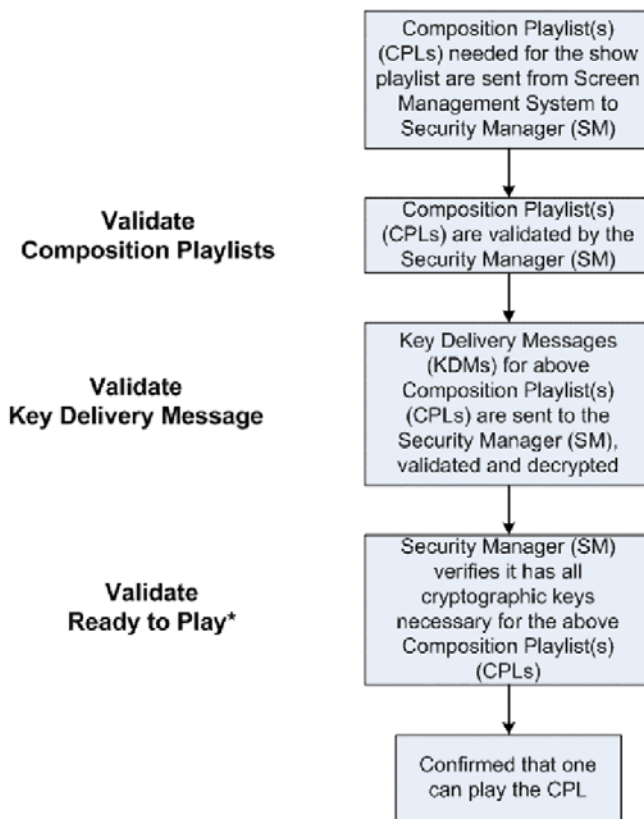

*"Ready to Play" may optionally include Key Delivery Message (KDM) playout window and/or Trusted Device List (TDL) checks

Figure 17: Pre-Show Overview

9.4.3.3. Show Playback

Show playback processes include auditorium preparations for the playback of a specific Show Playlist, and the actual run-time security functions that include content decryption at the Media Decryptor(s), link encryption/decryption, forensic marking, and recording of log data.

- **Equipment-Suite preparations** – The SMS and SM(s) shall prepare ~~the suite~~ for playback prior to each Show Playlist (SPL) composition showing. This shall include validation of the authenticity and "trust status" of ~~the suite~~ SPBs, and delivery of all necessary KDMs/keys per Section 9.4.3.5 Functions of the Security Manager (SM). ~~SMS shall obtain trust status by confirming that the SPBs are listed in the TDL delivered as part of each KDM required for the entire Show Playlist.~~ Different compositions may have different requirements and the system shall check the SPBs against the TDL for each composition independently.
- **Streaming media decryption** – Playback of a show consists of a concatenation of compositions that require serial or (separately) parallel decryption. One or more Media BlocksDecryptors (ie.eg., for single IMB or Multiple Media Block (MMB) operationimage, audio or subtitle) ~~will~~may be involved.
- **Link Encryption (LE) and Link Decryption (LD)** – If Link Encryption is used, the SM shall support keying of LE and LD Security Entities.
- **Forensic Marking** – Each MB shall apply Forensic Marking to image and audio data during playback.
- **Log data recording** – Media Blocks and rRemote SPBs shall capture ~~and transfer~~ log records ~~to the Image Media Block (IMB) SMS~~ as specified in Section 9.4.6.3 Logging Subsystem.

The flow chart in Figure 18: Show Playback Overview, is an example of how a system may execute a Show Playlist. This flow chart is informative. There are other designs that may have different steps or different sequences that will accomplish the same result and meet the requirements of this specification.

Show Playback Overview

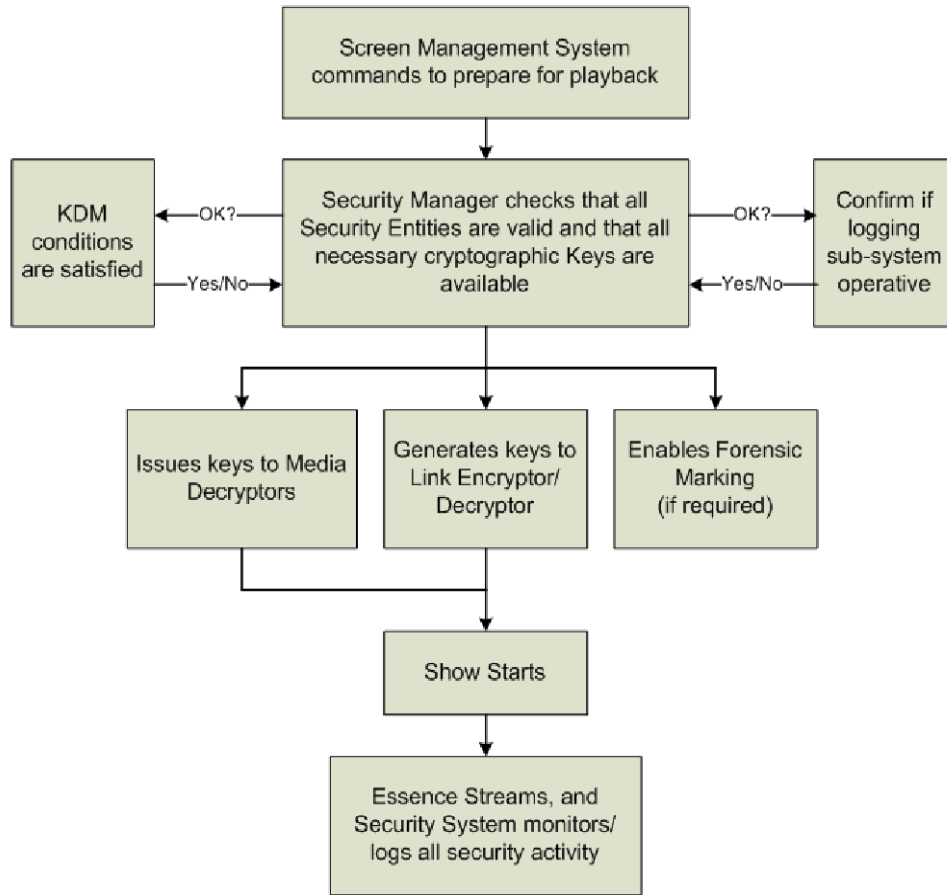

Figure 18: Show Playback Overview

9.4.3.4. Post Playback

Post playback activity primarily includes cleansing SPBs of sensitive data and collection of log data.

- **Media Decryptor and Link Decryptor content key zeroing** – MDs and LDs shall honor a validity duration period supplied with the keys provided by the SM, after which playback keys shall be purged⁸ from the respective SE.
- **Collection of log data** – ~~Each~~The Image Media Block SM shall be responsible for collection of all playback event log data from remote SPBs within the playback suite it supports per Section 9.4.6.3 Logging Subsystem.
- **Purge Suite** – The SMS shall be able to invoke a process that cleanses a suite of specific KDM content keys and suite preparations. This would be used as a last minute decision to change auditoriums, and/or to recover SPB memory storage, for

⁸ As used above and elsewhere in these specifications, the term purge shall mean the data is permanently erased or overwritten such that it is unusable and irrecoverable (also known as “zeroization” in FIPS 140-2).

example.

There are no end of engagement requirements placed on the security system. Exhibition may cleanse Screen Management System (SMS) or Theater Management System (TMS) devices, content storage devices, Key Delivery Message(s) (KDMs), etc. according to their own operational needs. Defined security system behavior places controls on Security Data, keys, etc. such that security interests are maintained.

The flow chart in Figure 19: Post Playback Overview, is an example of those items a system performs following a completed Show Playlist. This flow chart is informative. There are other designs that may have different steps or different sequences that will accomplish the same result and meet the requirements of the specification.

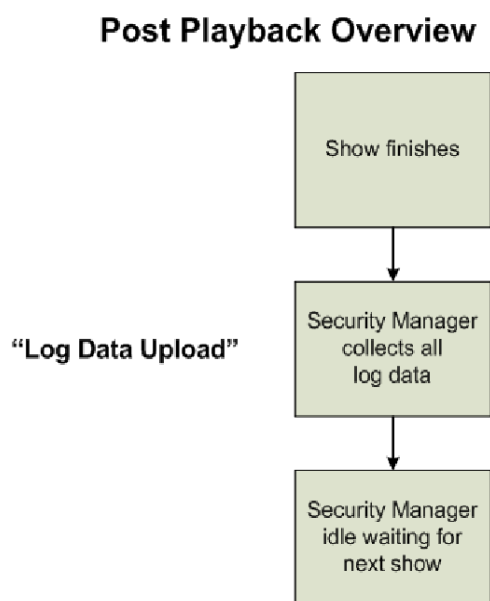

Figure 19: Post Playback Overview

9.4.3.5. Functions of the Security Manager (SM)

Auditorium Security Managers (SMs) are responsible for overseeing the security aspects of the auditorium they are assigned to (installed in), inclusive of the Secure Processing Blocks they are responsible for and according to the content essence types they are provided to process. For Multiple Media Block (MMB) situations multiple SMs will be present within an auditorium, and Each SM operates independently from other SMs in responding to the auditorium’s Screen Management System (SMS) to enable playback of content. The required SM functions are described below, from the perspective of each SM (i.e., not from the perspective of the auditorium). Depending upon the requirements for any given DCP, it will be recognized that for Multiple Media Block (MMB) auditorium situations the services of any single MB may not completely support playout of the DCP. However, individual compliance to these SM functions will assure playout is securely accomplished by the collective services of the auditorium MBs/SMs.

In listing these functions the approach is that of a reference model for SM behavior, meaning that these specifications do not define required implementation methods. A standards-

compliant implementation must, however, have the same input/output behavior as the reference model.

Security Manager (SM) Functions:

1. *Receive, store, decrypt and validate Key Delivery Message(s) (KDMs) per the three validity checks of Section 6.1.2 of the KDM specification (SMPTE430-1: D-Cinema Operations - Key Delivery Message). Constrain use of KDM content keys per items 4 and 9 below to the SM's confirmation that one of the certificates in the signer chain of the associated Composition Play List (CPL) has a thumbprint that matches the ContentAuthenticator element of the KDM, per Section 5.2.4 of said KDM specification.*
2. *Security Manager (SM) KDM usage policy is specified as follows:*
 - a. *For any given SM, playout within the associated Media Block (MB) shall be supported by a single KDM ~~inclusive of all required essence keys and playout time window~~ (i.e., a playout shall not occur that requires the combination of two or more KDMs). (Note that Multiple Media Block (MMB) operation will require multiple KDMs to support playout across multiple SMs/MBs. Since all KDMs for a given CPL must contain all the content keys for the composition (see Section 9.4.3 Theater Security Operations), depending upon its MB configuration the SM may find more essence keys in the KDM and identified in the CPL than it will use.)*
 - b. *For any given composition, playout shall be enabled for any start time that is within the KDM's time window.*
 - c. *To avoid end of engagement issues, a show time's playout may extend beyond the end of the KDM's playout time window, if started within the KDM playout time window, by a maximum of six (6) hours.*
 - d. *Excepting the requirements of item 2c above, the SM shall delete any KDM and associated keys for which the playback time window has expired (passed).*
3. *Reject ETM messages that are not recognized as DCI compliant standardized messages.*
4. *Validate Composition Playlists (CPL), and log results as a prerequisite to ~~preparing the suite for~~ the associated composition playback. For encrypted content, validation shall be by cross checking that the associated KDM's ContentAuthenticator element matches a certificate thumbprint of one of the certificates in the CPL's signer chain (see item 1 above), and that such certificate indicate only a "Content Signer" (CS) role per Section 5.3.4, "Naming and Roles" of the certificate specification (SMPTE430-2 D-Cinema Operation - Digital Certificate).*
5. *Process essence (i.e., Track File frame) integrity pack metadata for image and sound during show runtime. Integrity pack deviations (including HMAC, as applicable) detected during playback shall be logged; however, per Section 9.6.1.2 "Digital Rights Management: Security Manager" Table 21, playback should not be prevented or interrupted. For clarity purposes, integrity pack metadata is defined as Track File ID, Frame Sequence and calculated Message Integrity Code (MIC) information to be compared against the reference data contained in the associated CPL. Log information*

necessary to detect deviations (including restarts) from the actual playback sequence from the Track File ID and reel sequence specified in the CPL as follows:

- a. Image – Process integrity pack information, with the exception that the frame hash (HMAC) check is encouraged but optional.
- b. Audio – Process integrity pack information, including the hash (HMAC).

The SM shall prevent playout of encrypted content for which the image and sound integrity pack metadata is not present per the requirements of Section 5.3.2.1.

6. [This item left blank intentionally.]
7. Perform remote Secure Processing Block (SPB) and Screen Management System (SMS) authentication through Transport Layer Security (TLS) session establishment, and maintain the certificate lists so collected.
 - a. Associate certificate lists with TDLs delivered in KDMs per Section 5.2.5 of the KDM specification (SMPTE430-1: D-Cinema Operations - Key Delivery Message) to support the identification of security devices that are trusted/not trusted.
 - b. Maintain TLS sessions open for not more than 24 hours between complete restarts (i.e., forces periodic fresh TLS keys). Perform proxy mode of authentication for projection systems per Section 9.4.3.6.5.
 - c. Content owners may optionally allow the SM to automatically assume trust in remote SPBs (i.e., have the SM trust security devices without their certificate information appearing on the TDL). To support this feature, a unique "assume trust" certificate thumbprint is specified as the "SHA-1 of the empty string". The Base64 value of this string shall be "2jnj715rSw0yVb/vlWAYkK/YBwk=" for this exclusive use. When the KDM's DeviceList carries exclusively (only) the assume trust thumbprint, the SM shall consider the auditorium suite certificates collected during TLS session establishment as being "on the TDL." In other words, the SM shall act as if the TDL requirement has been satisfied. SM behavior shall otherwise follow all rules of this section. Should the KDM's DeviceList carry any thumbprint in addition to the assume trust thumbprint, the SM shall ignore this part (c) rule. The assume trust thumbprint shall not be used to enable Special Auditorium Situations per item 16 below.
8. Support TLS-protected ITM standards per Section 9.4.5.2 Intra-Theater Message Definitions. ITM functions shall include:
 - a. Maintain TLS sessions with suite SPBs (including the SMS),
 - b. Querying/receiving status of other SPBs external to the SM's Media Block,
 - c. ITM usage and operational behavior means with respect to item 8a and item 8b, sufficient to detect any equipment substitutions,
 - d. Reporting status on CPL playability, suite readiness and other SM and SPB conditions to the SMS,
 - e. Movement of security (or security related) information (e.g., content keys and LE keys, logging data, secure time).
9. Prepare and issue KDM-borne content keys to Media Decryptors (MD) ~~and Forensic Marking (FM) SEs as may require keying~~ per the CPL. Constrain use of keys to:

-
- a. Confirmation (via QuerySPB command) that TLS connections are operative with remote SPBs, and that the QuerySPB Response "general response" element indicator is "0" (RRP successful).
 - b. Usage validity periods of six (6) hours for remote SPBs (in line with the rule of item 2c above).
 - c. Authenticated and trusted Secure Processing Blocks (SPBs (per item 7 above). The system shall check the SPBs against the TDL for each composition independently.
 - d. Media Decryptors (MD) within the SM's SPB (i.e., under no circumstances shall an SM export any KDM-borne essence key from the SM's SPB). ~~[This item left blank intentionally.]~~
 - e. Specific MDs matching the key type IDs as designated by the KDM, per Section 5.2.8 of the KDM specification (SMPTE430-1: D-Cinema Operations - Key Delivery Message).
 - f. Receipt by the SM of a valid KDM and CPL for the composition being prepared for playback per items 1 and 4 above.
10. Support Link Encryption (LE) keying (if link encryption is used) by:
 - a. Generating unpredictable keys per Section 9.7.6 Key Generation and Derivation and having a usage validity period on a per-showing basis (i.e., each playout of an encrypted composition requires a new LE key.) which is generated per item 11 below.
 - b. Transferring LE keys only to an authenticated and trusted (per item 7 above) Link Decryptor Security Entity (SE) function.
 - c. Support link encryption operational processes for combinations of clear and encrypted content according to Section 9.4.4 Link Encryption.
 11. Perform suite playback preparations per items 9 and 10 above for each showing, within 30 minutes prior to show time. Though item 9 above establishes key validity periods of six hours, security equipment integrity checks and suite re-keying shall be executed within 30 minutes prior to each show time.
 12. Maintain secure time ~~for a specific auditorium~~, including remote SPB time synchronization requirements per Section 9.4.3.7 Theater System Clocks and Trustable Date-Time.
 13. Execute log duties ~~for the assigned auditorium~~ per Section 9.4.6.3 Logging Subsystem.
 14. Execute Forensic Marking (FM) control operations per Section 9.4.6-2 Forensics. ~~Marking Operations~~
 15. During all normal operating conditions (including during playback), continuously monitor and log integrity status of remote SPBs so as to preclude delivery of keys/content to, or playback on, compromised or improperly operating security equipment. To support this requirement the QuerySPB command (see Section 9.4.5. Intra-Theater Communications) shall be issued to each remote SPB at least every 30 seconds whenever TLS sessions are open. Receipt of a QuerySPB response indicating a "security alert" condition shall be indicative of a faulty SPB, and shall prevent or terminate playback per the DRM requirements of Section 9.6.1 Digital Rights Management. Once a show has started,

failure of a TLS link shall not cause termination of a show (i.e., QuerySPB commands will not successfully execute, but the show should continue to play if possible).

16. ~~[This item left blank intentionally.] Support suite playback such that no more than one projection system is enabled, except for content owner approved Special Auditorium Situations per the requirements of Section 9.4.4.1 "Special Auditorium Situations"~~
17. *The SM shall be "payout aware", meaning it shall have real-time knowledge of the occurrence of payout start and end periods. Secure Processing Block behavior and suite implementations shall permit the SM to prevent or terminate playback upon the occurrence of a suite SPB substitution or addition since the previous suite authentication and/or ITM status query. The SMs shall respond to such a change by immediately purging all content and link encryption keys, terminating and re-establishing: a) TLS sessions (and re-authenticating the suite), and b) suite playability conditions (KDM prerequisites, SPB queries and key loads). Perform the security equipment integrity checks and suite re-keying per item 11 above prior to the next playback.*
18. *Perform and log all the above functions under the operational (not security) control of the particular SMS designated by the exhibition operator per Section 9.4.2.5 Screen Management System (SMS).*

9.4.3.6. Functional Requirements for Secure Processing Block Systems

Each type 1 Secure Processing Block (SPB) can be considered an SPB system, since it operates as a collection of SEs. Similarly, the projector also has its associated type 2 SPB, which does not contain SEs, but fulfills security functions as described below. (Secure Processing Block types are defined in Section 9.4.2.2 The Secure Processing Block (SPB).) ~~In order to facilitate a composition playback, SPBs constituting the suite must work in a coordinated fashion under control of the suite's SM, contained within the Image Media Block (IMB).~~

~~Functional requirements of the SM are defined in Section 9.4.3.5 Functions of the Security Manager (SM).~~ This section defines the functions and operational requirements for the following SPB systems:

- Projector Secure Processing Block (SPB)
- Link Decryptor Block (LDB) Secure Processing Block (SPB)
- Image Media Block (IMB) Secure Processing Block (SPB)
- Outboard Media Block (OMB)
- LD/LE Device Secure Processing Block (SPB)

In addition to the specific requirements given for SPB systems in this section, all SPB systems shall meet the behavior requirements of Section 9.6.1 Digital Rights Management.

9.4.3.6.1. Normative Requirements: Projector Secure Processing Block

From a security perspective, a projection system consists of the projector Secure Processing Blocks (SPB) type 2 and its companion SPB, which will be either the Link Decryptor Block (LDB) or Image Media Block (IMB).

The following are the normative requirements for the projector Secure Processing Block (SPB):

-
1. *The projector's companion SPB (Link Decryptor Block or Image Media Block) shall be physically inside of, or otherwise mechanically connected to, the projector Secure Processing Block (SPB).*
 2. *The projector and Link Decryptor Block (LDB) Secure Processing Blocks (SPBs) shall be authenticated to the SM. However, authentication does not ensure that the two SPBs are mechanically connected to each other or ensure that an IMB/projector system is mechanically connected. Therefore, an electronic marriage shall take place upon installation of an IMB or LDB projector pair. This physical/electrical connection shall be battery-backed and monitored 24/7 by the companion SPB and, if broken, shall require a re-installation (re-marriage) process.*

Breaking the marriage shall not zero the projector SPB long term identity keys (RSA private), see item 7 below.

3. *Projector maintenance may involve a marriage (or re-marriage) event, or access to the projector SPB or both. To support projector maintenance, the projector SPB may be serviceable, but access is security-sensitive because of the possibility of tampering during service access.*

Once a projector is installed, projector SPB access door "open", access door "close", "marriage" and "marriage break" events shall be logged, and the "AuthID" token (see Section 9.4.6.3.8 Log Record Information) shall indicate the responsible exhibition party that executed (or supervised) the event(s). Once a projector is installed, all relevant projector SPB events of Section 9.4.6.3 Logging Subsystem shall be logged 24/7 under both powered and un-powered conditions.

To avoid the complexity of retaining its own log records (and the associated need for a clock and battery-backed persistence), the projector SPB shall send projector SBP log event data (i.e., [SPBOpen and SPBClose signals per Table 19 "Security Log Event Types and Subtypes"](#)) across the marriage electrical interface for retention by the companion SPB.

4. *Projector SPB designs shall not allow physical access to signals running between the companion SPB and the projector SPB without breaking the marriage, in which case a re-installation shall be required and tampering will be observed by the authorized installer (see Section 9.5.2.4 Specific Requirements for Type 2 Secure Processing Blocks).*
5. *The projector SPB shall accept the decrypted streaming image signal from either the Image Media Block (IMB) or Link Decryptor Block (LDB) SPB and process accordingly.*
6. *The projector SPB shall provide at least a type 2 image signal path and tamper/access protection container. The physical requirements for a type 2 SPB are given in Section 9.5.2.4 Specific Requirements for Type 2 Secure Processing Blocks.*
7. *The projector SPB shall include a Secure Silicon host device (see 9.5.2 Robustness and Physical Implementations) which shall contain the SPB's digital certificate.*

9.4.3.6.2. Normative Requirements: Link Decryptor Block (LDB)

The following requirements are normative where Link Encryption is used:

-
1. *As part of the installation (mechanical connection to projector and electrical initiation), perform electrical and logical marriage with the projector SPB. Electrical connection integrity between the Link Decryptor Block and the projector SPB shall be monitored 24/7. Should the integrity of the connection be broken, log the event and require a re-installation process before becoming active again.*
Breaking of the LDB/projector SPB marriage shall not zero the LDB SPB long-term identity keys (RSA private keys).
 2. *Perform content link decryption, and pass the decrypted streaming image to the appropriate circuitry inside the projector SPB. Link Decryptor Blocks shall be designed so as to not to perform link decryption functions unless married to a projector SPB.*
 3. *Respond to the Security Manager's (SM's) initiatives in establishing a Transport Layer Security (TLS) session and Link Decryptor Block authentication. Maintain this session until commanded to terminate.*
 4. *Link Decryptor Blocks (LDBs) shall not establish security communications with more than one SM at a time.*
 5. *The LDB shall contain a UTC time reference clock which is battery backed and operative for time stamping log events under powered and un-powered conditions. The LDB shall communicate time information with the SM using standardized Intra-Theater Messaging.*
 6. *Respond to SM "status" queries, and other Intra-theater Messages (ITMs) and SM commands as necessary to support SM behavior requirements.*
 7. *Accept and store link decryption keys, and associated parameters, provided by the SM. The LDB shall have the capacity to store at least 16 key/parameter sets.*
 8. *Purge LD keys upon expiration of the SM designated validity period, SM "purge" command, Link Decryptor Block SPB tamper detection, break of projector LDB SPB electrical connection, or change in TLS network parameters suggestive of an attack or equipment substitution.*
 9. *Record security event data for logging under both powered and un-powered conditions. Assemble logged information into standardized log records per Section 9.4.6.3 Logging Subsystem. The LDB shall support all logging functions of the projection system by providing 24/7 log recording support and storage of all log records associated with the projection system.*
 10. *Monitor Link Decryptor Block SPB physical security protection integrity 24/7. In the event of intrusion or other tamper detection, terminate all activity and zero all Critical Security Parameters (see Section 9.5.2.6 Critical Security Parameters and D-Cinema Security Parameters). Do not purge log records.*

9.4.3.6.2.1. Normative Requirements for LD/LE SPB Devices

The following requirements are normative where an SPB that performs link decryption followed by link encryption is used (see 9.4.4.1 Special Auditorium Situations):

-
1. *Within the LD/LE Device's type 1 SPB perimeter, perform link decryption followed by link encryption at the image essence input and output ports. Subject to the constraints of Section 9.4.4.1 "Special Auditorium Situations", multiple link encryption output ports may be implemented*
 2. *Respond to the Security Manager's (SM's) initiatives in establishing a Transport Layer Security (TLS) session and SPB device authentication. Maintain this session until commanded to terminate.*
 3. *LD/LE SPB Devices shall not establish security communications with more than one SM at a time.*
 4. *LD/LE SPB Devices shall contain a UTC time reference clock that is battery backed and operative for time stamping log events under powered and un-powered conditions. The SPB shall communicate time information with the SM using standardized Intra-Theater Messaging.*
 5. *Respond to SM "status" queries, and other Intra-Theater Messages (ITMs) and SM commands as necessary to support SM behavior requirements.*
 6. *Accept and store LD/LE keys, and associated parameters, provided by the SM. The SPB shall have the capacity to store at least 16 key/parameter sets.*
 7. *Purge LD/LE keys upon expiration of the SM designated validity period, SM "purge" command, SPB tamper detection, or change in TLS network parameters suggestive of an attack or equipment substitution.*
 8. *Record security event data for logging under both powered and un-powered conditions. Assemble logged information into standardized log records per Section 9.4.6.3 Logging Subsystem.*
 9. *Monitor LD/LE SPB Device physical security protection integrity 24/7. In the event of intrusion or other tamper detection, terminate all activity and zero all Critical Security Parameters (see Section 9.5.2.6). Do not purge log records.*

9.4.3.6.3. Normative Requirements: Image Media Block (IMB)

The following are normative requirements for the Image Media Block:

1. *Perform all SM functions as defined under Section 9.4.3.5 Functions of the Security Manager (SM).*
2. *Monitor IMB SPB physical security protection integrity 24/7. In the event of intrusion or other tamper detection, terminate all activity and zero all Critical Security Parameters (see Section 9.5.2.6). If communication with the SMS is available, issue an alert message. Do not purge log records.*
3. *When the IMB is integrated with the projector (i.e., is the projector's companion SPB), at the time of installation (mechanical connection to the projector and electrical initiation) the IMB shall perform and thereafter support electrical and logical marriage with the projector SPB per Section 9.4.3.6.1 Normative Requirements: Projector Secure Processing Block. Electrical connection integrity shall be monitored 24/7, and should the integrity of the connection be broken the IMB shall log the event and require a re-installation process before becoming active*

again. Breaking of the IMB/projector SPB marriage shall not zero the IMBs long-term identity keys (RSA private keys).

4. *Figure 15: Digital Cinema Auditorium Security Implementations of Section 9.4.1 presents the two fundamental security system architectures as auditoriums 1 and 2: an integrated projection system architecture (no link encryption), and a link encryption architecture, respectively. In the first instance the Integrated Media Block (IMB) outputs clear text content. An IMB intended to operate with an integrated projection system shall be designed such that it does not perform any composition decryption functions until integrated and married to a projector SPB. An IMB intended for non- integrated operation shall be designed to not be reconfigurable to operate with an integrated projection system.*
5. *Perform media decryption for image, audio and subtitle essence. Perform forensic marking for image and audio essence. The IMB may optionally perform the content essence processing functions defined in Section 9.4.3.6.4 “Normative requirements: Outboard Media Block (OMB)”. In such case IMB forensic marking shall implement both embedded and KDM-borne FMID requirements of Section 9.4.6.1.1 “General Requirements.”*
6. *After image decryption and Forensic Marking (and other non-security plain text functions as appropriate by design), pass the image signal to the projector SPB or link encryption function, as appropriate. In the latter case the image signal shall undergo link encryption per Section 9.4.4 “Link Encryption.” Subject to the constraints of Section 9.4.4.1 “Special Auditorium Situations,” multiple link encryption output ports may be implemented.*
7. *Record security event data for logging under both powered and un-powered conditions. Sign and assemble logged information into standardized log reports ~~records~~ per Section 9.4.6.3 Logging Subsystem. When integrated within a projector as the projector's companion SPB, the IMB shall provide 24/7 log recording support and storage of all log records associated with the projector SPB.*

9.4.3.6.4. Normative Requirements: OutboardAudio Media Block (OMB)

The following are the normative requirements for the Outboard Media Block:

~~Per Section 9.4.2.3 Media Blocks (MBs), audio decryption shall be performed within the Image Media Block (IMB).~~

1. Perform the following itemized SM functions as defined under Section 9.4.3.5 “Functions of the Security Manager (SM)”: # 1, # 2, # 3, # 4, #5, # 9 (except for sub-items a and c), # 12, # 13, # 14, # 18.
2. Monitor OMB SPB physical security protection integrity 24/7. In the event of intrusion or other tamper detection, terminate all activity and zero all Critical Security Parameters (see Section 9.5.2.6). If communication with the SMS is available, issue an alert message. Do not purge log records.
3. Perform media decryption on encrypted essence, and forensic marking as applicable on essence prior to outputting clear text content from the SPB. OMB forensic

marking shall implement both embedded and KDM-borne FMID requirements of Section 9.4.6.1.1 "General Requirements."

4. Content essence type(s) are limited to those explicitly listed as follows:

- Object-Based Audio Essence (OBAE) as defined in the Digital Cinema Object-Based Audio Addendum published by Digital Cinema Initiatives, LLC (DCI) on September 9, 2013.

5. Record security event data for logging under both powered and un-powered conditions. Sign and assemble logged information into standardized log reports per Section 9.4.6.3 Logging Subsystem.

9.4.3.6.5. Projector Authentication

Where link encryption is used, authentication of the projection system to the SM is required. The "proxy mode" of authentication is herein defined as the use of the companion LDB and its TLS session to proxy for the projector SPB.

Proxy mode authentication of the projection system is accomplished as follows: LDB certificate information is delivered to the SM during the LDB's TLS session initiation handshake. The projector's certificate information is subsequently delivered to the SM using the GetProjCert Standardized Security Message (see Section 9.4.5.2.4 "Request Response Pairs").

For married projection systems that use link encryption, projection system authentication shall be according to proxy mode. The SM shall ensure that both the LDB and projector SPB certificate thumbprints are on the TDL prior to enabling payout.

When the SM is the companion SPB (i.e., architectures with no link encryption), the projector's certificate information shall be obtained by the SM directly over the marriage connection. The SM shall ensure that the projector certificate thumbprint is on the TDL prior to enabling payout.

9.4.3.6.6. Permanently Married Implementations

This section assumes that the LDB and IMB are implemented as field replaceable SPB modules. It is not mandatory, however, that they be implemented in this fashion. It is allowed, for example, for the LDB to be permanently married to a projector, and not field replaceable. In such a case where the projector and its companion SPB (LDB or IMB) are not field separable, there is no marriage event, and thus no reason to monitor whether the marriage connection is broken. This relieves the companion SPB from marriage monitoring duties, but does not change the requirement for IMB or LDB equivalent SPB functions, and the projector SPB, to meet the respective SPB type 1 and type 2 physical and logical protection requirements of Section 9.5 Implementation Requirements, and the normative requirements as specified above, except as the latter requirements relate to marriage event and connection monitoring.

In the case where the Projector and companion SPB are inseparable, a single Digital Cinema Certificate shall represent both the Projector and its companion SPB (Image Media Block or

Link Decryptor Block). For dual certificate implementations this shall be the Security Manager Certificate (see Section 9.5.1 Digital Certificates).

Implementations that do not meet the marriage functions, per the normative requirements of this section, shall not permit field replacement of the IMB or LDB security function as appropriate according to which function is the companion SPB to the projector, and shall require the projector SPB and companion SPB system to be replaced in the event of an SPB failure.

A deviation from these requirements shall be considered non-compliant and a "Security Function Failure" (see Section 9.5.5 Compliance Testing).

Note: For permanently married implementations where there are no remote SPBs the KDM need not carry Trusted Device List (TDL) information. The KDM syntax requirement that the associated "DeviceList" element not be empty can be satisfied by placing any Digital Cinema certificate thumbprint in this field.

9.4.3.7. Theater System Clocks and Trustable Date-Time

Note: Nothing in this section shall require that the user interfaces of the SMS or TMS use UTC. It is envisioned that these will use local time.

To ensure playback times and event log time stamps are time-accurate, means must exist to distribute and maintain proper security system time. Time shall mean UTC (Coordinated Universal Time). See ASN.1 standard syntax for transferring time and date data "GeneralizedTime" and "UTCTime".

- All security transactions conferring date-time information (e.g., KDM time window) shall be UTC.

Image Media Block (IMB) and Outboard Media Block (OMB) Security Managers shall each be responsible for maintaining secure and trusted time for their respective MBs for the auditorium to which they are assigned (installed). ~~Additional~~The security system clock requirements are:

- The Image Media Block (IMB) SM shall be responsible for establishing and maintaining time for the auditorium ~~E~~equipment ~~S~~suite it supervises.
- Each ~~Image Media Block (IMB and OMB) SM~~ clock shall be set by the ~~SMB~~ vendor to within one second of UTC using a reference time standard (such as WWV). The clock shall be tamper-proof and thereafter may not be offset from UTC or otherwise reset.⁹
- In order to maintain synchronism between auditoriums, Exhibition shall be able to adjust a Security Manager's time a maximum of +/- six minutes within any calendar year. Time adjustments shall be logged events.
- Remote SPBs type 1 shall have internal UTC time clocks, and maintain time-awareness 24/7 under both powered and un-powered conditions. The IMB Security Manager shall track the time difference between remote SPB clocks and its internal clock by issuance of the "GetTime" standardized security message of Table 15 "Intra-

⁹ A limited-magnitude adjustable time offset to this clock is described in the subsequent point.

Theater Message Request-Response Pairs" at least once per day.

- *The IMB and OMB Security Manager (SM) clocks shall have the following capabilities:*
 - *Resolution to one second*
 - *Stability to be accurate +/- 30 seconds/month*
 - *Date-Time range at least 20 years*
 - *Battery life of at least 5 years*
 - *Battery can be changed without losing track of proper time*
 - *Proper time stamping of log events shall not be interrupted during a clock battery change process.*
- *Remote SPB clocks shall meet the same capabilities as the SM clock, except the stability requirements are +/- 60 seconds per month. Exhibition shall be able to adjust a remote SPB's time a maximum of +/- fifteen minutes within any calendar year. Time adjustments shall be logged events.*

9.4.4. Link Encryption

Link Encryption shall be used at all times (i.e., for encrypted and clear text content) where image content is carried on interconnecting cables, which are exposed (i.e., outside of an SPB) downstream from image media decryption. *The Security Manager (SM) shall enforce link encryption operations per the requirements of this section in all applications except for fully integrated architectures (i.e., "Auditorium 1" configuration of Figure 15: Digital Cinema Auditorium Security Implementations).*

Where Link Encryption is used (i.e., Auditorium 2 Figure 15: Digital Cinema Auditorium Security Implementations), the Image Media Block (IMB) SM shall provide link encryption keys for use with the Link Encryptor (LE) and Link Decryptor (LD) Security Entities (SE) located within the IMB and Link Decryptor Block (LDB) SPBs respectively. Authentication of the LDB by the IMB SM (see Security Manager and LDB requirements of Section 9.4.3.5 Functions of the Security Manager (SM) and Section 9.4.3.6.2.1 Normative Requirements for LD/LE SPB Devices) shall be performed to ensure that link keys are provided only to legitimate devices which appear on the KDM Trusted Device List (see Section 9.6.2 "Trust" and the Trusted Device List (TDL)). *Link Encryption keys shall be delivered to the LDB using the appropriate category 2 standardized security messages of Table 15 Intra-Theater Messages Request-Response Pairs.*

In the case of playback of clear text content (as indicated by the CPL), no KDM is required, and in such a case no TDL will exist. Recognizing that combinations of clear text and encrypted content must be accommodated, the following rules define normative Link Encryption functionality:

- In any instance where content is not encrypted and no KDM for this content exists, the SM shall automatically assume "trust" in the LDB and projector SPBs for purposes of keying the LDB and enabling playback for (only) that CPL. All logging processes shall take place normally, recognizing that some logging events (e.g., no logging of content key use) will not be recorded.
- In instances where combinations of encrypted and non-encrypted content constitute a Show Playlist, the SM shall require the LDB and projector to appear on

the TDL prior to enabling keying Link Encryption functions and enabling playback for any CPL having encrypted content.

Link Encryption shall be implemented according to RDD 20-2010 SMPTE Registered Disclosure Document: "CineLink 2 Specification." Link Encryption keys shall be generated according to the requirements of Section 9.7.6 Key Generation and Derivation. Link Encryption keys shall be distributed using the appropriate Standardized Security Messages of 9.4.5.2.4 Request-Response Pairs (and shall not be distributed using in-band techniques). The individual requirements of this specification shall take precedence over RDD 20-2010 as a whole.

It is mandatory that a fresh Link Encryption key be used for each movie showing (i.e., each playout of an encrypted composition requires a new LE key.) Multiple Link Encryption keys may be used for showings, and in such cases, it is encouraged that different LE keys be distinguished by (used according to) the CPL (where different Composition Playlists constitute a showing). In the case where multiple LE keys are used, it will be necessary for the industry to standardize on a single technique to identify which LE key is to be used for which portion(s) of any given showing.

9.4.4.1. Special Auditorium Situations

"Special Auditorium Situations" are defined to allow the Image Media Block (IMB) to operate with more than a single projector. Special Auditorium Situations shall be enabled by the following methods:

- *IMB with Multiple Link Encryption means the use of (i) more than one remote LDB/projector pair with a single IMB, or (ii) an LD/LE image processor SPB inserted between the IMB and one or more remote LDB/projector pair(s).*
- *Integrated IMB with Link Encryption means the use of an integrated and married IMB/projector pair, where the IMB also outputs a Link Encrypted image signal to one or more remote LDB/projector pair(s). The IMB shall simultaneously meet all requirements for both integrated and non-integrated projector system implementations.*

IMB SMs shall enable Special Auditorium Situations to operate only when the SM receives a KDM whose Trusted Device List (TDL) contains only the identities of the SPBs it is enabling for playback. For IMB with Multiple Link Encryption operation these shall be the remote SPBs identified during TLS authentication (see details below). For Integrated IMB with Link Encryption this additionally includes the identity of the projector to which the IMB is married. This matching is an indication to the SM that Special Auditorium Situations operation has been approved by the content owner.

IMB with Multiple Link Encryption operation or Integrated IMB with Link Encryption operation shall follow all normal (single) Link Encryption requirements of this section, with the following additional requirements:

- a. *SM behavior shall be designed to identify a Special Auditorium Situation during the auditorium security network TLS session establishment. The digital certificate exchange with remote SPBs shall return the associated certificate roles for each SPB in the auditorium.*
- b. *The SM shall independently authenticate each remote SPB against the TDL using a dedicated TLS session.*

-
- c. *The SM shall independently key each remote SPB for Link Encryption operation using standardized Intra-Theater (security) Messaging per Section 9.4.5.*
 - d. *The SM shall not support the use of more than one LD/LE image processor SPB for any given projector.*
 - e. *The Link Encryption stages of the LD/LE image processor configuration may use the same LE key(s). Similarly, the SM may key the multiple LDB/projector configuration using the same LE key for each LDB/projector system.*

9.4.5. Intra-Theater Communications

This Section discusses requirements for communications necessary to support security functions in each auditorium. Depending upon facility communications network designs, there may be both intra-auditorium as well as theater-wide networks and these may be physically one network. The security system requires and addresses only the intra-auditorium network, over which Intra-Theater (security) Messages (ITM) are employed.

Intra-Theater Message(s) (ITMs) are described for communications between the SMS and SM(s), and between the SM(s) and remote Secure Processing Blocks (SPBs). *The Image Media Block (IMB) shall support all ITMs as defined in this section. The Outboard Media Block (OMB) shall only support ITMs between the SMS and OMB (the OMB does not support Link Encryption or authenticate remote SPBs and thus shall not support Auditorium Security Messaging). ~~Note that, depending upon SPB designs, the numbers of SPBs used, and the mix of Security Entities (SEs) within them may vary.~~*

9.4.5.1. Transport Layer Security Sessions, End Points and Intra-Theater Messaging

The SM and SMS shall both conduct their intra-theater security messaging under TLS protection (IETF RFC 2246).

All TLS end points shall be within the physical protection perimeter of the associated SPB. No SPB requirements are placed on the SMS.

9.4.5.2. Intra-Theater Message Definitions

This section identifies the set of Intra-Theater Messages standardized by this specification. *These are required to support interoperability and normative operational and security behavior of SPB systems.*

9.4.5.2.1. Intra-theater Message Hierarchy

The following hierarchy for Intra-Theater Messaging (ITM) is defined:

- Transactions – Describe the interactions between exhibition components (Security Entities) and the system state changes that occur as a result of the transaction.
- Request/Response Pairs (RRP) – Describes a single interaction between the SEs. *At least one RRP is required to implement a transaction.*
- Messages – A data structure that passes between SEs. An RRP consists of a request message and a resultant response message.

A transaction consists of sequences of RRP, and RRP are pairings of messages. A transaction is an interaction, or series of interactions (RRPs) that change the state in one or more participating SEs in a consistent manner. Transactions need not be standardized. In assembling transactions, the sequences of RRP used may vary according to the equipment vendor or facility configuration. *Transactions shall be "idempotent" (such a transaction may be repeated without changing its outcome).* Thus, if the initiator of a transaction does not receive evidence of satisfactory completion, it may safely initiate the transaction again without fear of unexpected consequences.

RRP standards do not apply inside of Secure Processing Blocks (SPBs), however RRP concepts are developed assuming that a Security Entity (SE) will exist logically within a SPB, even if not distinctly in hardware. *The SPB is allowed to proxy for any SE (within it) in the support of security messaging.*

9.4.5.2.2. Terms and Abbreviations

The following abbreviations and terms are used in this ITM section:

- Requester = initiator of an RRP
- Responder = answers the RRP
- UDP & TCP = IP protocols for delivering blocks of bytes (UDP) or stream of bytes (TCP)

9.4.5.2.3. General RRP Requirements

1. *Only the SMS or SM shall set up Transport Layer Security (TLS) sessions. TLS session establishment between SMS and SM may be initiated by either party. Except where noted, only the SMS or SM shall initiate RRP.*
2. *Security Managers (SMs) shall not communicate with SPBs other than those in its Equipment Suite, and SPBs shall not communicate with SMs other than the one assigned to their suite.*
3. *During normal operations, remote Secure Processing Blocks (SPBs) shall maintain their TLS communications sessions with the SM open and active at all times.*
4. *Absence of a response after an RRP is directed to a SPB over an active TLS session represents a network failure or SPB fault condition. Playback shall continue under network failure conditions to the extent possible.*
5. *Unless otherwise noted, an RRP response is allowed to be busy or an unsupported message type, and such a response shall not be an error event.*
6. *No broadcast RRP commands shall be used or required.*
7. *Except where noted, non-TLS security communications shall not be allowed, and production Digital Cinema security equipment shall have no provisions for performing security functions in a TLS "bypass" mode.*
8. *RRP protocols shall be synchronous: Each pairing shall be opened and closed before a new RRP is opened between any two devices. Nested transactions (in which one end point must communicate with another end point while the first waits) are allowed.*

-
9. *Standardized security messages (Category 2 messages of Table 15) shall use, and have exclusive use of, well-known port 1173 (which has been reserved for SMPTE digital cinema use by the Internet Assigned Numbers Authority [IANA]). Operational messages (Category 1 messages of Table 15) shall not use well-known port 1173, but shall operate under TLS.*
 10. *Equipment suppliers may implement proprietary ITM, however such ITM shall not communicate over well-known port 1173 (i.e., any non-standardized ITM shall use a different port).*
 11. *Equipment suppliers shall define and describe their respective security designs surrounding the use of well-known port 1173 per the requirements of FIPS 140-2 per Section 9.5.2.5 FIPS 140-2 Requirements for Type 1 Secure Processing Blocks.*

9.4.5.2.4. Request-Response Pairs (RRP)

Table 15: Intra-theater Message (ITM) Request-Response Pairs (RRP) lists "standardized security messages" (category 2) and suggested "operational messages" (category 1). *The following establishes the implementation requirements for these message types:*

- **Standardized Security Messages** - *Standardized security messages shall be compliant to SMPTE 430-6 D-Cinema Operations - Auditorium Security Messages, and shall consist only of messages listed as category 2 messages of Table 15: Intra-theater Message (ITM) Request-Response Pairs (RRP). These messages are used between the Image Media Block and remote SPBs, with the IMB as the Requestor (RRP initiator). The security data and related information that is the subject of these messages shall be communicated only via standardized security messages.*
- **Operational Messages** - *The implementation of operational messages is not normatively specified. However, to support log event recording (see 9.4.6.3 Logging Subsystem), it shall be mandatory that Security Managers functionally support Table 15: Intra-theater Message (ITM) Request-Response Pairs (RRP) category 1 operational messages. This means that the SM must be capable of performing the function, whether via ITM command, or other control means. The functional approach shall specify an "AuthorityID", which is intended to indicate the SMS operator, per Section 9.4.2.5 Screen Management System (SMS).*

The term "Auditorium Security Messages" (ASMs) in SMPTE 430-6 corresponds to the term "standardized security messages" in this specification. The combination of the terms "standardized security messages" and "operational messages" are referred to in this specification as Intra-Theater Messages (ITMs).

Message Category	Function
1. SMS to SM StartSuite StopSuite CPLValidate KDMValidate TimeAdj	<i>Suggested operational messages</i> Commands SM to establish TLS sessions with remote SPBs Commands SM to terminate TLS sessions with remote SPBs Requests that the SM perform a CPL validation check Requests that the SM perform a KDM validation check Adjusts time at SM (within annual limits)
2. IMB SM to SPB BadRequest GetTime GetEventList GetEventID QuerySPB LEKeyLoad LEKeyQueryID LEKeyQueryAll LEKeyPurgeID LEKeyPurgeAll GetProjCert	<i>Standardized security messages</i> Special "Response" indicating failure to process a "Request" Requests a snapshot of a remote SPBs absolute (UTC) time Requests a list of logged event IDs for a specified time window Requests the return of a specified logged event by ID Interrogates a remote SPB as to health and status Delivers one or more LE keys to a Link Decryptor Block (LDB) Interrogates the LDB for the presence of a specified LE key Requests a report of all active LE keys by key ID Commands the LDB to purge a specified LE key Commands the LDB to purge all active LE keys Requests the LDB to deliver a copy of the projector certificate

Table 15: Intra-theater Message (ITM) Request-Response Pairs (RRP)

9.4.5.3. Intra-Theater Message Details

This section provides particular requirements for specific messages.

9.4.5.3.1. Screen Management System to Security Manager Messages

[This section left blank intentionally.]

9.4.5.3.2. Image Media Block Security Messaging

Image Media Block to remote SPB messages are category 2 Intra-Theater Messages of Table 15: Intra-theater Message (ITM) Request-Response Pairs (RRP). Standardized security messages are defined in SMPTE 430-6 D-Cinema Operations - Auditorium Security Messages. The following requirements are in addition to those in SMPTE 430-6:

- *SPB security devices shall be designed to meet the round trip latency requirements suggested in SMPTE 430-6.*
- *A remote SPB shall respond to the QuerySPB command (i.e., the "ResponderBusy" general response element code "3" is not permitted). To meet this requirement, vendors are encouraged to assure that adequate message processing periods exist between this and other RRP command types.*
- *The following QuerySPB "security alert" conditions are defined, and shall be reported per status code "2" of this command's response:*
 1. *SPB perimeter open (e.g., service access door).*
 2. *Marriage broken event detected (see Section 9.4.3.6.1. Normative Requirements: Projector Secure Processing Block).*

3. *Conditions that require replacement of the SPB (i.e., equipment tampering or failure) per Section 9.6.1.3. Digital Rights Management: Security Entity (SE) Equipment.*

- *The LEKeyLoad command “expire time” shall be 6 hours per Section 9.4.3.5. Functions of the Security Manager (SM), Item 9.b.*
- *When performing TLS 1.0 handshake mutual authentication, it shall be permissible for the TLS client and server devices to deliver only the respective SPB device leaf certificate.*
- *For mutual authentication during TLS session establishment in dual certificate Image Media Block (IMB) implementations (see Section 9.5.1.2 Dual Certificate Implementations) the SM shall present IMB certificates as follows:*
 1. *SM establishes the TLS session with a remote SPB (SM is the “TLS client”) - The Log Signer Certificate (LS Cert) shall be presented.*
 2. *SMS establishes the TLS session with SM (SM is the “TLS server”) - The SM Certificate (SM Cert) shall be presented.*
- *The GetProjCert RRP command of Table 15 shall be implemented as follows:*

GetProjCert Command

The GetProjCert command returns the projector SPB certificate from the Link Decryptor Block (LDB) over the LDB's TLS connection with the Security Manager. *The certificate returned shall be from the projector (SPB) to which the LDB is currently married. This command shall fail if the LDB is not in an actively married state. (The references to SMPTE 430-6 are informative.)*

GetProjCert Request

Item Name	Type	Length	UL	Description
GetProjCert Request	Pack Key	16		Identifies the GetProjCert Request *
Request Length	BER Length	4		Pack Length
Request ID	Uint32	4		ID of this request

* Bytes 12 and 13 shall be 02 and 18. (See SMPTE 430-6, Tables A-1, A-2)

GetProjCert Response

Item Name	Type	Length	UL	Description
GetProjCert Response	Pack Key	16		Identifies GetProjCert Response *
Response Length	BER Length	4		Pack Length
Request ID	Uint32	4		ID of the request for which this is the response
Projector Certificate Data	Byte Array	Variable		DER encoded certificate
Response	Uint8	1		Response Info **

The length of the certificate is determined from the length of the response.

* Bytes 12 and 13 shall be 02 and 19. (See SMPTE 430-6, Tables A-1, A-2)

** Response (see SMPTE 430-6 Section 6.3):

- 0 - RRP successful
- 1 - RRP failed
- 2 - RRP Invalid
- 3 - ResponderBusy

Table 16: Left Intentionally Blank

Table 17: Left Intentionally Blank

Table 18: Left Intentionally Blank

9.4.6. Forensics

Forensics do not prevent content theft or other compromises, but rather, it provides methods for their detection and investigation. Forensic features deter attackers who are aware that their actions would be logged and/or reported in considerable detail.

Forensic features fall into two classes: Forensic Marking (FM) and logging. Forensic Marking embeds tracking information into content itself, to be carried into subsequent legitimate or stolen copies. Logging creates records of both normal and abnormal events in the Distribution and Exhibition process. During a content theft investigation, both FM and logging information may be combined to establish the details of the security compromise.

Industry terminology for watermarking and Forensic Marking is not consistent. For these security specification purposes, stakeholders have agreed to use the term Forensic Marking for all content marks.

9.4.6.1. Forensic Marking

These specifications require that image and audio Forensic Marking (FM) capability be included in each Image Media Block. The security system identifies content marking devices (e.g., Forensic

Marking embedders) as the “FM” Security Entity (SE) type. To support FM processes, standardized Intra-Theater Messaging (ITM) may be used where needed for communications between such SEs and Security Managers (SMs). Such communications and associated FM behavior is outside of this specification. *However the requirements of ITM Section 9.4.5 Intra-Theater Communications shall be mandatory where such theater messaging employs the intra-auditorium security network.* Forensic Marking does not require interoperability between detection systems, as the detection operation is usually performed “off line” as part of a security investigation.

Multiple solutions may be qualified and will allow Media Block solutions providers to select the solution of their choice. Candidate providers should meet with individual studios to discuss RAND and technical suitability of their approach.

Note: DCI reserves the right, at some future time, to require a specific Forensic Marking insertion solution for Digital Cinema systems.

At a minimum, Forensic Marking systems are required to meet the following:

9.4.6.1.1. General Requirements

- *The Forensic Marking data payload is required to be a minimum of 35 bits and must contain the following information:*
 - *Time stamp every 15 minutes (four per hour), 24 hours per day, 366 days/year the stamp will repeat annually. There are 35,136 time stamps needed, therefore allocate a 16 bit unsigned number (65,536).*
 - *Location (serial number) information, allocated 19 bits (524,000 possible locations/serial numbers)*
- *All 35-bits are required to be included in each five minute segment.*
- *Forensic Marking insertion is required to be a real-time (i.e., show playback time), in-line process performed in the associated media block, and is required to have a reasonable computational process.*
- *Recovery can take up to a 30-minute content sample for positive identification.*
- *Support of a single distribution inventory is required.*
- *Terms and conditions of use are required to be reasonable and non-discriminatory (RAND).*
- *Detection can be performed by the vendor or the Rights Owner at the Rights Owner’s premises.*
- *DCI will entertain development of a generic Forensic Mark inserter architecture. Any FM technology utilizing pre-processing is required to use a generic inserter architecture that meets the criteria outlined below. Additionally, a full understanding of the intellectual property terms and conditions will need to be reached.*
 - *Standardized Metadata Format – Any pre-processing solution is required to be able to utilize a single, industry standardized metadata transport format and a generic inserter solution.*

-
- *Title (Composition) Single Inventory* – For each composition, the system is required to support the use of a single image or audio FM technology that generates one set of metadata. This metadata is required to be compatible with all deployed compliant generic inserters. At the distributor’s discretion, multiple sets of metadata can be used to mark the same composition.
 - *Generic Inserter Compatibility* – For the initial generic inserter deployment, the generic inserter in final product form is required to be openly demonstrated and independently tested to demonstrate compatibility with a minimum of three independent metadata-based forensic marking solutions.
 - *Forensic Mark and Generic Inserter Backwards Compatibility* – After initial deployment, any subsequent metadata-based FM solutions or generic inserters are required to function correctly with all deployed compliant systems.
 - *Forensic Mark Pre-Processing Speed* – The Forensic Mark processing steps needed to generate and insert metadata are required to be real time or faster and are required to occur in a single pass.
 - *As a matter of implementation, recognizing business and post-production constraints, it is encouraged that a generic inserter implementation minimizes the metadata payload needed to provide forensic mark data to the generic inserter. A reasonable target would be less than two percent of the compressed image and sound data payload.*
 - *Each instance of a Forensic Marking application shall include a unique 19 bit minimum “location” Forensic Marking Identification (FMID). The FMID value shall be derived in one of two ways as follows:*
 1. *When the KDM’s KeyIdList contains a KeyType element whose value is “FMID”, the FM application shall use the lower 19 bits of the 128 bit “AES Content Decryption Key” field encrypted in that KDM’s corresponding CipherValue element. There shall only be one such KeyType element found in a KDM.*
 - *The delivered FMID parameter shall be logged by the MB’s SM, and made available per the log report protocol of Section 9.4.6.3 Logging Subsystem. The FMID value shall be logged as an element so named, and included as part of (i.e., in addition to) the KDMKeysReceived Record of SMPTE 430-5 D-Cinema Operations - Security Log Event Class and Constraints for D-Cinema.*
 - *It is the responsibility of KDM creators to coordinate with each other and the industry to ensure the uniqueness of KDM-borne FMIDs.*
 2. *When the KDM carries no such KeyType element, the FMID value shall be derived from an embedded unique parameter associated with the Forensic Marking application. The FMID shall meet the following requirements:*
 - *The embedded Forensic Mark shall be manufactured-in such that the FMID cannot be changed or reprogrammed by any means whatsoever without violation of the SPB’s type-1 perimeter.*

- Manufacturers of SPBs containing Forensic Markers shall maintain and make available an accurate, timely database associating each embedded FMID with its associated SPB serial number and digital certificate.
- Forensic Marking licensors shall ensure the uniqueness of FMIDs.
- To support multiple projection situations, it is the responsibility of KDM creators to assure that each participating Forensic Marking application be supplied with the same KDM-borne FMID value. This value and the accompanying Forensic Mark time stamp shall be used to generate an identical Forensic Mark from each projector, each mark being frame-by-frame synchronized between projectors. Time stamps shall be synchronized such that each Forensic Mark time stamp is identical, and each time value increment occurs in synchronism across the participating projectors throughout the playout (SPB clock drift shall not result in different time stamps). The optically combined synchronized Forensic Marks as projected shall meet the same “general” and “survivability” requirements as defined herein for single projector applications.
- ~~Forensic Marking shall be permanently associated with the Image Media Block that contains it. To enforce this association, the following requirements are mandatory:~~
 - ~~Each instance of a Forensic Marking application shall be assigned a unique Forensic Marking Identification (FMID).~~
 - ~~Forensic Marking shall be manufactured such that the FMID cannot be changed or reprogrammed by any means whatsoever without violation of the IMB's SPB 1 perimeter.~~
 - ~~Manufacturers of Image Media Blocks shall maintain and make available an accurate, timely database associating each FMID with its associated IMB serial number and IMB digital certificate.~~
 - ~~Forensic Marking licensors shall insure the uniqueness of FMIDs.~~

9.4.6.1.2. Image/Picture Survivability Requirements

- *Image Forensic Marking is required to be visually transparent to the critical viewer in butterfly tests for motion image content.*
- *Is required to survive video processing attacks, such as digital-to-analog-digital conversions (including multiple D-A/A-D conversions), re-sampling and re-quantization (including dithering and recompression) and common signal enhancements to image contrast and color.*
- *Is required to survive attacks, including resizing, letterboxing, aperture control, low-pass filtering and anti-aliasing, brick wall filtering, digital video noise reduction filtering, frame-swapping, compression, scaling, cropping, overwriting, the addition of noise and other transformations.*
- *Is required to survive collusion, the combining of multiple videos in the attempt to make a different fingerprint or to remove it.*

- *Is required to survive format conversion, the changing of frequencies and spatial resolution among, for example, NTSC, PAL and SECAM, into another and vice versa.*
- *Is required to survive horizontal and vertical shifting.*
- *Is required to survive arbitrary scaling (aspect ratio is not necessarily constant).*
- *Is required to survive camcorder capture and low bit rate compression (e.g. 500 Kbps H264, 1.1 Mbps MPEG-1).*

9.4.6.1.3. Audio Survivability Requirements

- *Audio Forensic Mark is required be inaudible in critical listening A/B tests.*
- *The embedded signal is required to survive multiple Digital/Analog and Analog/Digital conversions.*
- *Is required to survive radio frequency or infrared transmissions within the theater.*
- *Is required to survive any combination of captured channels.*
- *Is required to survive resampling and down conversion of channels.*
- *Is required to survive time compression/expansion with pitch shift and pitch preserved.*
- *Is required to survive linear speed changes within 10% and pitch-invariant time scaling within 4%.*
- *Is required to survive data reduction coding.*
- *Is required to survive nonlinear amplitude compression.*
- *Is required to survive additive or multiplicative noise.*
- *Is required to survive frequency response distortion such as equalization.*
- *Is required to survive addition of echo.*
- *Is required to survive band-pass filtering.*
- *Is required to survive flutter and wow.*
- *Is required to survive overdubbing.*

9.4.6.2. Forensic Marking Operations

There may be differing circumstances surrounding the desire by a Rights Owner to forensically mark content. To accommodate these variations, it is necessary to be able to independently control the activation of both the audio and the image Forensic Marking (FM). *The following rules shall be normative for Forensic Marking operations:*

1. *The SM shall be solely responsible for control of FM marking processes (i.e., "on/off") ~~for the auditorium it is installed in~~, and, subject to item 2 below, command and control of this function shall be only via the KDM per item 3 below.*
2. *Forensic Marking shall not be applied to non-encrypted audio or image content. If portions of a composition are encrypted and other portions are not, FM shall not be applied to those Track Files that are not encrypted.*

-
3. *Forensic Marking shall otherwise be applied to all encrypted picture and audio content, except as follows:*
 - a. *The "no FM mark" and "selective audio FM mark" state shall be commanded by the 'ForensicMarkFlagList' element of the KDM.*
 - b. *When the KDM 'ForensicMarkFlagList' indicates the "no FM mark" command, the FM device(s) shall enter a full bypass mode, and shall not alter the content essence for the associated encrypted DCP.*
 - c. *When the KDM 'ForensicMarkFlagList' indicates the "selective audio FM mark" command, the audio FM device(s) shall not impose, in the associated encrypted DCP, any mark onto audio channels above the channel indicated in the command, per (d) below. This paragraph shall override (b) above if both the "no FM mark" and "selective audio FM mark" commands are present.*
 - d. *The "selective audio FM mark" command shall be indicated by the presence of a ForensicMarkFlag element containing a URI of the form:
<http://www.dcimovies.com/430-1/2006/KDM#mrkflg-audio-disable-above-channel-XX> where XX is a value in the set {01, 02, 03, 04, 05, 06, 07, 08, 09, 10, 11, 12, 13, 14, 15, 16 ... 99} and corresponds to a channel identifier within the track, per 382M-2007 table E.1, as wrapped in a Sound Track file of the associated encrypted DCP. URIs of this form shall be used in conjunction with keys of KeyType "MDAK". A KDM shall carry only one such ForensicMarkFlag element.*
 4. *"No FM mark" states shall be capable of being independently commanded for audio or image compositions.*
 5. *When commanded, the "no FM mark" state shall apply to the entire encrypted DCP. The "no FM mark" state shall not apply to any other DCP, even if the other DCP is part of the same showing (i.e., same Show Playlist).*
 6. *[This item left blank intentionally.]*
 7. ~~*[This item left blank intentionally.] SM control of the Forensic Marking "no FM mark" state in remote SPBs shall be communicated via a Table 15 category 2 standardized security Intra-Theater Message (see Section 9.4.5. Intra-Theater Communications).*~~
 8. *The SM and FM Security Entities shall log the presence or absence of audio and image Forensic Marking for each encrypted DCP.*
 9. *Notwithstanding the exceptions defined in Section 9.4.6.2, all audio essence shall be forensically marked, up to sixteen channels.*

9.4.6.3. Logging Subsystem

In the Exhibition environment, the preparations for and execution of a movie showing creates information that has security and forensic implications. The capturing and storage of such information is the responsibility of the logging subsystem. In order to realize a "control lightly/audit tightly" end-to-end security environment, the security system includes a secure logging subsystem.

Cryptographic technology as applied to essence and key delivery, together with agreed upon usage rules provides the “control lightly” characteristics. The function of a logging subsystem is to respond to the “audit tightly” requirement. Logging is therefore observed as a critical component of security, and secure logging information and surrounding processes are subject to the same fundamental cryptographic requirements as the front end control components: cryptographic protection of critical functions and data components related to integrity, data loss, confidentiality and movement.

This section sets the logging subsystem requirements for security log data recording and reporting. *The log information data formats and structures to be used in conjunction with these requirements are defined in two SMPTE standards:*

- *SMPTE 430-4 D-Cinema Operations - Log Record Format Specification for D-Cinema*
- *SMPTE 430-5 D-Cinema Operations - Security Log Event Class and Constraints for D-Cinema*

SMPTE 430-4 defines the general format for log classes for digital cinema. SMPTE 430-5 defines the specific requirements for the security log class. *All log requirements and terminology of this section are with respect to the SMPTE 430-5 security events class constraints specification.*

Definitions related to logging:

- Log Event – Any event that has security implications or forensic value. Such an event results in the recording of log data.
- Log Data – Security event information that is recorded and stored within the Security Entity (SE), where such an event took place or was observed.
- Log Record – Standardized XML structure representing a discrete logged event.
- Log Report – Standardized XML structure containing one or more log records spanning a continuous sequence in time. The log record content in a report is intended to be organized by class, and may be filtered prior to delivery according to specified criteria (Rights Owner, CPL, etc.).

Following the above definitions, a basic logging process is described:

- Surrounding a showing will be a number of security events that result in logged data. *Discrete logged event data shall be placed in an XML structure called a record.*
- A number of records are collected in sequence and by class to make up log reports.
- A complete (unfiltered) report is useful for transferring entire sets of log data for archiving or post-processing outside of the security system.
- A “filtered” report is useful for responding to a request for log data according to specified bounds (e.g., report the SE key usage records for CPL(id) for specific date(s) and time(s)).
- Reports may be delivered via the theater network using log messages (Intra-theater Messages), or simply transferred to a physical device (e.g., USB removable flash memory).

9.4.6.3.1. Logging Requirements

1. Logging subsystem implementations shall not affect the ability of Exhibition to operate their projection systems in a standalone fashion.
2. Security Entities (SE) shall have normative requirements for the specific log data to be recorded for each record (see Section 9.4.6.3.7 Security Log Reports and Section 9.4.6.3.8 [Log Record Information](#)).
3. Log records and reports shall be protected from undetected alteration (integrity and authentication) or deletion (continuity).
4. Log records and reports shall be non-repudiable and traceable back to the source SE device (i.e., where the logged event took place).
5. Log records and reports shall carry proof of authenticity, which does not rely on the trustworthiness of the systems and channels they pass through. Systems or devices which communicate, handle or store log messages (or records) need not be trusted or secure.
6. The content of log records shall be protected from exposure to parties other than the intended recipient (see Section 9.4.6.3.6 Log Filtering).
7. Each Rights Owner shall be able to cryptographically confirm the integrity and continuity of log records and their log data independently of other Rights Owners (see Section 9.4.6.3.6 Log Filtering).
8. Image Media Block SMs shall collect log information from all remote Secure Processing Blocks in the suite it enables at the earliest equipment idle time between scheduled showings. To assure timely collection, TLS sessions shall not be terminated prior to collection of all remote SPB log data, and in no event shall more than 24 hours pass between the recording of log data by a remote SPB and the collection of such data by the IMB Security Manager.
9. The Image Media Block shall internally store at least twelve (12) months of typical log data accumulation ~~for the auditorium in which it is installed~~, including log data collected from the associated remote SPBs. [The OMB shall also internally store at least twelve \(12\) months of typical log data.](#)
10. Remote Secure Processing Blocks (SPBs) shall have sufficient secure storage to hold log data to accommodate at least two days' worth of typical operation.
11. Log records stored in SPBs shall be stored in non-volatile memory and not be purgeable. Data shall be over-written beginning with the oldest data as new log data is accumulated. In no event shall remote SPB log records be overwritten prior to them being collected by the SM.
12. An SE shall author its own log records, or utilize the services of a proxy within the same secure SPB.
13. SEs or their SPB proxy shall have an asymmetric identity key pair and Digital Cinema certificate for signing log records. Log records shall be signed only by ~~the~~ Security Manager (SM) [providing the log report\(s\)](#).
14. SEs or their proxy shall time stamp log records, with date/time synchronized with the ~~auditorium~~ SM's secure clock. The accuracy of the time stamp relative to the actual

event shall not exceed one (1) second. Accuracy shall mean the latency between the occurrence of the event and the indicated time stamp.

15. SEs or their proxy shall sequence log records with a secure and persistent counter.

16. ~~The~~ ~~Image Media Block~~ ~~and Outboard Media Block~~ Security Managers (SM) shall each associate (identify) all ~~suite~~ log records with the SMS under which each operates.

17. Any use of a proxy in the above, shall produce log records compliant to these requirements.

9.4.6.3.2. Log Record and Report Format

Log record and report formats shall be compliant with SMPTE 430-5 D-Cinema Operations – Security Log Event Class and Constraints for D-Cinema.

9.4.6.3.3. Log Signatures and Integrity Controls

Log signatures and integrity controls shall be compliant with SMPTE 430-5 D-Cinema Operations - Security Log Event Class and Constraints for D-Cinema.

For dual certificate ~~Image Media Block (IMB)~~ implementations (see Section 9.5.1.2 Dual Certificate Implementations), the following requirements are in addition to those in SMPTE 430-5:

- The LogReport element shall contain the reportingDevice child element as defined in SMPTE 430-4 "D-Cinema Operations - Log Record Format Specification". The reportingDevice element shall be completed as follows (see SMPTE 433 "D-Cinema - XML Data Types"): In the case that the DeviceIdentifier element contains a UUID, the DeviceCertID element shall also be present and shall contain the certificate thumbprint of the SM Certificate. In the case that the DeviceIdentifier element is a certificate thumbprint, it shall contain the certificate thumbprint of the SM Certificate. In either case the certificate thumbprint of the Log Signer Certificate shall be present in the AdditionalID element, encoded as an XML Schema ds:DigestValueType type.
- Log records shall be signed per the requirements of SMPTE 430-5 section 6.2 "Log Record Authentication and Chaining" using the device's Log Signer Certificate.

9.4.6.3.4. Security of Log Record Sequencing

Log record sequencing shall be compliant with SMPTE 430-5 D-Cinema Operations - Security Log Event Class and Constraints for D-Cinema.

9.4.6.3.5. Log Upload Protocol over Theater Networks

Auditorium suites using Link Encryption shall transfer log records from remote Secure Processing Blocks (SPB) to that auditorium's Image Media Block (IMB) SM using the GetEventList and GetEventID standardized security messages of Table 15 "Intra-Theater Message Request-Response Pairs"

Per Section 9.4.3.7 Theater System Clocks and Trustable Date-Time, the Security Manager collects UTC time-stamped reports from remote SPBs via the GetTime standardized security

message. The SM shall use the GetTime information to calculate the difference between true time (the SM's time) and time in the remote SPB, and remove the difference in reporting remote SPB event data. The reporting (export) of log information from the IMB shall be by XML structure that is compliant with SMPTE 430-5 D-Cinema Operations - Security Log Event Class and Constraints for D-Cinema.

9.4.6.3.6. Log Filtering

Log record and/or report filtering processes shall be compliant with SMPTE 430-5 D-Cinema Operations - Security Log Event Class and Constraints for D-Cinema.

For distribution of log information, it may be necessary to filter log content so that log ~~records or~~ reports can be generated that supply log record content selectively to the appropriate recipients. The location(s) where log data filtering takes place (e.g., in the Image Media Block (IMB), Outboard Media Block (OMB) or in external theater-controlled devices or processes) is an implementation decision.

9.4.6.3.7. Security Log Reports

~~The Image~~-Media Block ~~(IMB)~~ Security Managers shall provide (export) log event information in the form of log reports (not log records) as defined in SMPTE 430-5 D-Cinema Operation - Security Log Event Class and Constraints for D-Cinema.

The EventID (see SMPTE 430-4 D-Cinema Operations - Log Record Format Specifications) shall be a single, invariant value that uniquely identifies each logged event. For avoidance of doubt, for a given event the EventID shall be the same value each time it appears in a log report.

9.4.6.3.8. Log Record Information

The logging subsystem shall follow the requirements for specific log data to be recorded as defined in SMPTE 430-5 D-Cinema Operations - Security Log Event Class and Constraints for D-Cinema. SMPTE 430-5 defines the following data types for the "Security Class" category of log information:

EventType - Identifies a log record as being associated with one of a Payout, Validation, Key, ASM or Operations event.

EventSubType - Specifies what information is to be logged for each Event Sub Type record.

Each Secure Processing Block (SPB) type shall log the Event Sub Type records as shown in Table 19 Security Log Event Types and Subtypes.

	<u>IMB</u>	<u>OMB</u>	<u>LDB</u>	<u>LD/LE SPB</u>	<u>Proj. SPB</u>
<u>Playout Event Sub Types</u>					
<u>FrameSequencePlayed</u>	<u>X</u>	<u>X</u>			
<u>CPLStart</u>	<u>X</u>	<u>X</u>			
<u>CPEnd</u>	<u>X</u>	<u>X</u>			
<u>PlayoutComplete</u>	<u>X</u>	<u>X</u>			
<u>Validation Event Sub Types</u>					
<u>CPLCheck</u>	<u>X</u>	<u>X</u>			
<u>Key Event Sub Types</u>					
<u>KDMKeysReceived</u>	<u>X</u>	<u>X</u>			
<u>KDMDeleted</u>	<u>X</u>	<u>X</u>			
<u>ASM Event Sub Types</u>					
<u>LinkOpened</u>	<u>X</u>		<u>X</u>	<u>X</u>	
<u>LinkClosed</u>	<u>X</u>		<u>X</u>	<u>X</u>	
<u>LinkException</u>	<u>X</u>		<u>X</u>	<u>X</u>	
<u>LogTransfer</u>	<u>X</u>		<u>X</u>	<u>X</u>	
<u>KeyTransfer</u>	<u>X</u>		<u>X</u>	<u>X</u>	
<u>Operations Event Sub Types</u>					
<u>SPBOpen</u>					<u>X¹⁰</u>
<u>SPBClose</u>					<u>X¹⁵</u>
<u>SPBMarriage</u>	<u>X¹¹</u>		<u>X</u>		
<u>SPBDivorce</u>	<u>X¹⁶</u>		<u>X</u>		
<u>SPBShutdown</u>	<u>X</u>	<u>X</u>	<u>X</u>	<u>X</u>	
<u>SPBStartup</u>	<u>X</u>	<u>X</u>	<u>X</u>	<u>X</u>	
<u>SPBClockAdjust¹²</u>	<u>X</u>	<u>X</u>	<u>X</u>	<u>X</u>	
<u>SPBSoftware</u>	<u>X</u>	<u>X</u>	<u>X</u>	<u>X</u>	
<u>SPBSecurityAlert</u>	<u>X</u>	<u>X</u>	<u>X</u>	<u>X</u>	

	IMB	LDB	LD/LE SPB	Proj. SPB
--	------------	------------	------------------	------------------

¹⁰ The SPBOpen and SPBClosed event types shall be detected by the projector SPB, and logged and reported by the projector's companion SPB.

¹¹ Applicable when no Link Encryption is used.

¹² Applicable if the SPB has a clock that is adjustable.

Playout Event Sub-Types				
FrameSequencePlayed	X			
CPLStart	X			
CPEnd	X			
PlayoutComplete	X			
Validation Event Sub-Types				
CPLCheck	X			
Key Event Sub-Types				
KDMKeysReceived	X			
KDMDeleted	X			
ASM Event Sub-Types				
LinkOpened	X	X	X	
LinkClosed	X	X	X	
LinkException	X	X	X	
LogTransfer	X	X	X	
KeyTransfer	X	X	X	
Operations Event Sub-Types				
SPBOpen				X ¹³
SPBClose				X ¹⁵
SPBMarriage	X ¹⁴	X		
SPBDivorce	X ¹⁶	X		

¹³The SPBOpen and SPBClose event types shall be detected by the projector SPB, and logged and reported by the projector's companion SPB.

¹⁴Applicable when no Link Encryption is used.

SPBShutdown	X	X	X	
SPBStartup	X	X	X	
SPBClockAdjust ¹⁵	X	X	X	
SPBSoftware	X	X	X	
SPBSecurityAlert	X	X	X	

Table 19 Security Log Event Types and Subtypes

¹⁵—Applicable if the SPB has a clock that is adjustable.

In addition to the requirements specified in SMPTE 430-5, the following shall be normative for DCI compliance:

- *SPBs shall log each of the "Exception" events identified in the EventSubType Record descriptions for the applicable Event Sub Type records per Table 19. The SPB shall record the appropriate Exception record(s) as specified in the SMPTE 430-5 EventSubType definitions.*
 - *Recorded Exception token(s) shall include those that prevent an EventSubType from occurring. (For example, LinkOpened and FrameSequencePlayed EventSubTypes define Exceptions that prevent the link from opening or playout from occurring.)*
 - *For the CPLCheck and KDMKeysReceived EventSubTypes, SMPTE 430-5 requires certain values from the input document to be recorded as parameters of the log record. In the case that an exception is recorded for these EventSubTypes, syntactically recognizable data items in the input document shall be recorded. (For example, when a KDMFormatError is recorded because the KDM's signing certificate has expired but the document is otherwise valid, the KDM's MessageId shall be present in the log record.)*
- *The SPBSecurityAlert Operations EventSubType shall be recorded for conditions that require replacement of the SPB (i.e., equipment tampering or failure) per Section 9.6.1.3 Digital Rights Management: Security Entity Equipment.*
- *The AuthID token for the Playout Event Sub Type events shall carry the value indicated by the SMS AuthorityID per Section 9.4.2.5 Screen Management System. Per section 9.4.2.6 Projection Systems, the AuthID token for the Operations Event Sub Type events shall indicate the identity of the authority figure responsible for the event.*

9.4.6.3.9. FIPS 140-2 Audit Mechanism Requirements

FIPS 140-2 requirements (see Section 9.5.2.5 FIPS 140-2 Requirements for Type 1 Secure Processing Blocks) require audit (logging) mechanisms for certain modifiable operating system environments for cryptographic modules. These specifications restrict the SPB operating environment to non-modifiable modes of implementation. Thus there are no additional FIPS 140-2 related logging requirements for Exhibition security devices for normal Digital Cinema operations.

Logging requirements for SPB firmware code changes shall be implemented per Section 9.5.2.7 SPB Firmware Modifications. These device-change log records shall be accessible using the log record specifications as given in this section.

9.4.6.3.10. Logging Failures

The secure logging subsystem is required to be operable as a prerequisite to playback. Security Managers (SMs) shall not enable for playback (i.e., key) any suite for which it has not collected log records from Secure Processing Blocks (SPBs) per Section 9.4.6.3.1 Logging Requirements item (8), or if there is any indication that a next playback will not record and

report log records as required. Behavior of security devices (SPB or SE) shall be specified and designed to immediately terminate operation, and require replacement, upon any failure of its secure logging operation. Resident log records, in failed SPBs and SEs shall not be purgeable except by authorized repair centers, which are capable of securely recovering such log records.

9.5. Implementation Requirements

9.5.1. Digital Certificates

Digital certificates are the means by which the Security Manager (SM) identifies other security devices. They are also used to sign security log records and in establishing Transport Layer Security (TLS) connections. This specification originally required each Secure Processing Block (SPB) to carry a single digital certificate to support each of these requirements. However, in some circumstances (e.g., new equipment designs and/or upgrades) evolving Federal Information Processing Standards (FIPS) have imposed the need for use of a second digital certificate within ~~the Image Media Blocks (IMB)~~. (FIPS requirements are addressed in Sections 9.5.2 Robustness and Physical Implementations and 9.7 Essence Encryption and Cryptography.)

To maintain compliance with FIPS requirements, this specification now includes requirements for both single and dual IMB certificate use. Equipment vendors shall solicit FIPS expertise for guidance as to which approach is required for their implementation.

All Digital Cinema certificates shall use the X.509, Version 3 ITU standard (see [ITU-T Recommendation X.509 (1997 E): Information Technology – Open Systems Interconnection – The Directory: Authentication Framework, June 1997, and RFC3280]). Detailed specifications for Digital Cinema digital certificates are given in Section 9.8. Except as otherwise specified below, the requirements for all digital certificates (i.e. both single and dual use implementations) shall be the same.

9.5.1.1. Single Certificate Implementations

Single certificate implementations shall employ one Digital Cinema certificate in each Secure Processing Block (SPB). The requirements for use of a single SPB certificate are provided in the appropriate sections of this specification.

The identity of a device shall be represented by its certificate. The make and model of each certificated device shall be carried in the assigned certificate, and the serial number and device role(s) (see below) shall in particular be carried in the Common Name (CN) field of the assigned certificate. The make, model and serial number of each certificated device shall be placed on the exterior of said device in a manner that is easily read by a human.

Each SPB shall enumerate the security functions of the SPB according to SMPTE 430-2 D-Cinema Operations – Digital Certificate, section 5.3.4 Naming and Roles. For purposes of efficiency, SE types shall be minimally designated according the following roles ~~(the designation of other roles is optional)~~:

- Image Media Block (IMB) – SM
- Image Media Block with Link Encryptor – SM LE

- KDM-borne FMID capable IMB – SM FM
- KDM-borne FMID capable IMB with OBAE – SM OBAE
- KDM-borne FMID capable IMB with LE – SM FM LE
- KDM-borne FMID capable IMB with OBAE & LE – SM OBAE LE
- Outboard Media Block with OBAE processor – OBAE
- *Link Decryptor Block – LD*
- *Image Processor – LD LE*
- *Projector to be married – PR*
- Projector permanently married to an IMB – PR SM
- *Projector permanently married to an LDB – PR LD*

Notes:

- The designation of other roles is optional.
- This specification requires that MBs which process OBAE essence be KDM-borne FMID-capable (see Section 9.4.3.6, Functional Requirements for SPB Systems).

9.5.1.2. Dual Certificate Implementations

Dual (two) certificates are used only with the Image Media Block (IMB) and Outboard Media Block (OMB), and no other SPB types are affected. Dual certificate implementations split the utility of digital certificates between the two certificates. *Dual certificate utility shall be as follows:*

- Security Manager Certificate (SM Cert) – *The SM Cert shall be used according to the same requirements as those for the above Section 9.5.1.1 Single Certificate Implementation, except for those functions specified for the below Log Signer Certificate. The SM Cert shall be the certificate associated with the identity of the Media Block and shall be the target of Key Delivery Messages (KDM).*
- Log Signer Certificate (LS Cert) – *The LS Cert shall be used to 1) sign security log records per the requirements of Section 9.4.6.3.3. “Log Signatures and Integrity Controls” and 2) perform TLS session establishment functions per the requirements of 9.4.5.3.2 “Image Media Block Security Messaging.” Details of these requirements are provided in the noted sections.*

The Log Signer Certificate shall enumerate roles only as follows:

- *LS – Log Signer; all implementations*
- *LS LE – Log Signer for IMB with Link Encryptor*

In addition to the above, dual certificate implementations require Digital Cinema certificate validation rules that may not be reflected in the current SMPTE digital cinema specification (see DCI Digital Cinema System Specification v. 1.2 with Errata as of 30 August 2012 Incorporated Page 143

DCSS Section 9.8, SMPTE 430-2: “D-Cinema Operations – Digital Certificate”). The affected validation rule is driven by the “Key Usage” constraints as given in Table 2 of SMPTE 430-2 (“Field Constraints for Digital Cinema Certificates”), which is then reflected in validation rule # 6 of section 6.2 “Validation Rules”. *For dual certificate implementations validation rule # 6 shall be as stated in SMPTE 430-2 for single certificate implementations, except as follows:*

- *SM Cert – The DigitalSignature flag shall not be set.*
- *LS Cert – The KeyEncipherment flag shall not be set.*

Note to reader: There are no changes between Section 9.5.1.2 and 9.5.3.

9.5.3. Screen Management System (SMS)

There are no physical constraints or requirements imposed on the SMS by the security system (i.e., no SPB requirements); however, the SMS implementation shall not otherwise weaken or effect the security operations of other Security Entities or SPBs.

9.5.4. Subtitle Processing

See Section 9.7.3 Subtitle Encryption.

9.5.5. Compliance Testing

Compliance Testing is the process of qualifying Secure Processing Blocks (SPBs) and their Security Entities for use in Digital Cinema systems. All SPBs shall be subject to qualifying criteria in the following areas:

- *Compliance to Intra-Theater Messaging (ITM) specifications – The SPB and internal logical SEs shall interpret and respond to the standard ITM message set according to the appropriate Section 9.4.5.2.4 Request-Response Pairs (RRP) category as specified herein.*
- *Image Media Blocks (IMB) and Outboard Media Blocks (OMB) shall support compliance with standardized Extra-Theater Messaging (ETM) specifications, in addition to the above compliance requirement for ITMs.*
- *~~The~~ Security Managers and Secure Processing Block systems shall meet the applicable functional requirements as specified in Sections 9.4.3.5 Functions of the Security Manager (SM) and 9.4.3.6 Functional Requirements for Secure Processing Block Systems, respectively.*
- *Compliance to SPB physical and logical requirements – Each SPB shall be evaluated against physical and logical requirements based on the SPB type per Section 9.5.2 Robustness and Physical Implementations, including FIPS 140-2 requirements as applicable.*

Device vendors shall issue Digital Cinema certificates only to devices that comply with this specification.

A device that does not meet all of the above criteria shall not be installed in a DCI compliant Digital Cinema system. A device that does not continue to meet all the above criteria shall be declared a Security Function Failure, and shall be taken out of service until repaired.

9.5.6. Communications Robustness

The following are required for the exhibition of content and security communications, and communications networks:

- *Theater networks shall protect security system(s) from the threat of external and internal network-borne attacks by the use of appropriate firewalls. At a minimum, each auditorium shall have such firewall protection for any communications interface(s) connecting to the intra-auditorium security network. In particular, such firewall protection shall prevent (filter) communications to or from any well-known port 1173, other than directly between security equipment within a single auditorium.*
- *Digital Cinema security messages and content shall not be carried over a wireless network, but shall be carried over wire or optical cables.*
- *The portions of the network used to carry any security messages or content shall be logically or physically separated from any wireless network device. At a minimum, a properly configured firewall shall separate the wired network that carries security messages or content from any wireless network operated at the same facility.*
- *The network cabling or cabling trough should not be publicly accessible on the premises.*

9.6. Security Features and Trust Management

This section describes the standardized Digital Cinema security operational features, and how “trust” is communicated and enforced to ensure security features are reliably executed. A security policy is what results once the variables that develop, from the overall security system design and implementation, are constrained according to desired operational characteristics. An open architecture security system should not dictate any specific policy, but enable stakeholders to agree on one more policies that support business needs. Once policy has been decided, it can be described operationally as the security feature set.

9.6.1. Digital Rights Management

This section identifies various features and functions that describe the operation of the security system. For each auditorium ~~equipment suite~~, the security system consists of three types of components involved in Digital Rights Management (DRM):

- 1) The Screen Management System (SMS)
- 2) The Security Manager(s) (SM)
- 3) The associated security equipment (e.g., Media Block(s), Link Decryption Block)

The last two components have access to, and process, Digital Cinema security information (secrets), such as content keys or plain text content. They are the primary subject of these security specifications. The Screen Management System does not have access to such secrets. But because the Screen Management System initiates security-related activity, it is considered a participant in security events.

The basic business philosophy is to “control lightly, audit tightly.” Per this philosophy, a movie will fail to playback only under four circumstances:

- 1) Wrong location) (see Table 21: Examples of Security Manager Events)
- 2) Wrong date and time (outside the engagement window) (see Table 21: Examples of Security Manager Events)
- 3) Unauthorized device (equipment is not accepted by the content owner) (see Table 21: Examples of Security Manager Events)
- 4) Failure of, or tampering, with security equipment (see Table 22: Examples of Failure or Tampering of Security Equipment)

Compliance to security system logging requirements ensures that all events having security implications will generate associated log records that are stored in the ~~Image~~ Media Block(s). These log records can be accessed by the exhibitor’s Screen Management System, and reports can be provided to appropriate distributors under contractual obligations.

All three types of security system components (Screen Management System, Security Manager, security equipment) have defined roles and responsibilities (e.g., to perform their security functions and generate log records), and overall security depends upon their proper operation. The descriptions below detail the three types of security system components. Included in the Security Manager and security equipment description are tables showing possible security system operational scenarios and how the system responds to a particular issue.

The tables are also designed to be informative to parties interested in understanding business issues in relation to the Digital Cinema security system. It shows that the security system’s reach is limited to only those areas necessary for ensuring persistent protection of content and security data (keys), enabling content to play within a designated time window, and the provisioning of reliable log data (see Table 21: Examples of Security Manager Events and Table 22: Examples of Failure or Tampering of Security Equipment).

9.6.1.1. Digital Rights Management: Screen Management System

The Screen Management System is responsible for managing Exhibition functions such as showtime movie playback, and is under the control of the Exhibitor. The Screen Management System manages playback functions via the Security Manager(s), however the Security Manager is at all times in control of and responsible for security functions and events. The full compliment of Exhibition operational events therefore consists of those under the control of the Security Manager(s) and those under the control of the Screen Management System.

9.6.1.2. Digital Rights Management: Security Manager (SM)

~~The Security Manager is the executor of Digital Rights Management for each auditorium. It controls content keys and the delivery of such keys to the appropriate security equipment to~~

~~enable playback of encrypted content.~~

The Security Manager is the executor of Digital Rights Management for the Media Block that contains it. In addition, the Image Media Block (IMB) is also responsible for each Secure Processing Block (SPB) in the associated Equipment Suite. Security Managers control content keys and the delivery of such keys to the appropriate Security Entities (SE) to enable playback of encrypted content. ~~Each Security Manager (and the Image Media Block it is part of) is assigned to a single projector.~~ Keys are considered active for the business defined play period. Subject to security equipment authentication, proper operation, and integrity checks (see Section 9.4.3 Theater Security Operations), the Security Manager exercises no control over playback, other than content key delivery during the valid play period. Under private business negotiations, a Distributor may provide keys for selected or all Security Managers (i.e., projectors) in a complex.

... End of Chapter 9 (security chapter) redlines ...

7. THEATER SYSTEMS

(Changed sections only)

Note to the reader: In conjunction with the above Chapter 9 redlines, MMB operation and MB-to-MB synchronization is further supported by the following DCSS Chapter 7 redlines. These have been published concurrently with the above as normal DCSS errata; they are included herein for convenience.

7.5.4 Media Block

7.5.4.1. Introduction

Another key component in the playback chain is the Media Block. One or more Media Blocks are responsible for converting the packaged, compressed and encrypted data into raw image, sound and subtitles.

Depending upon implementation, both security and non-security functions take place within Media Blocks. Security functions of Media Blocks (those functions which process plain text essence or Security Data such as decryption keys) may take place only within physically secure perimeters called Secure Processing Blocks (SPB). The more general functions of the Media Block and variations on implementation are described here. Not all such functions are required to be within an SPB. Detailed security requirements of Media Blocks are discussed in Section 9.4 Theater Systems Security.

The Image Media Block can be implemented in a server configuration, as shown in Figure 11. This is where the storage and the Image Media Block are closely coupled. In this configuration, the content data is then pushed to the ~~final projector playback device~~. *In this configuration, Link Encryption is required to protect the uncompressed content.*

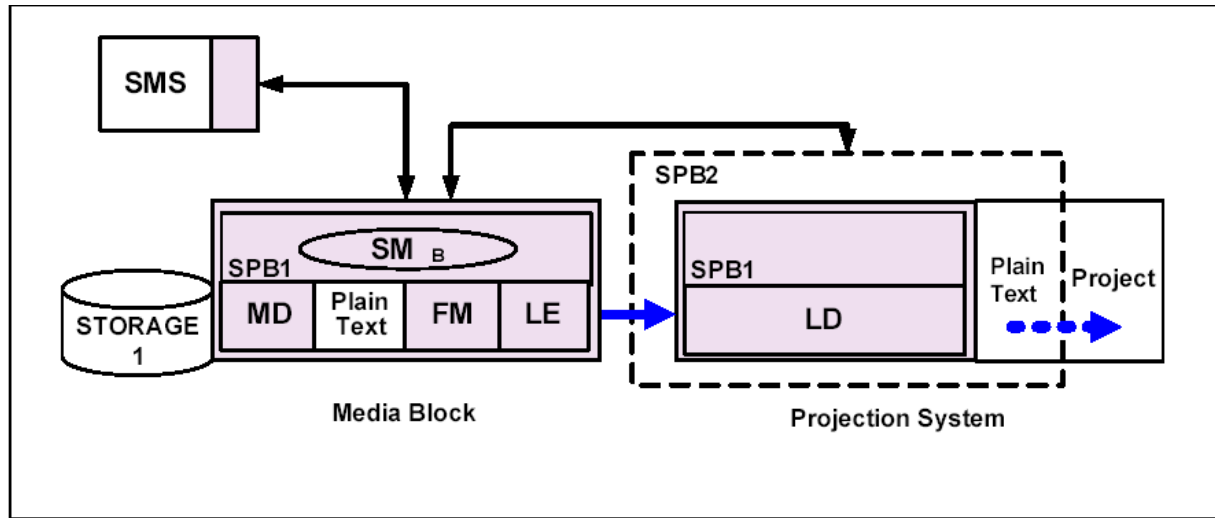

Figure 11: Media Block Server Configuration

Note to the reader: Figure 11 has been updated as follows: Two edits for “AUDITORIUM 2”: Removed (1) the asterisk from “FM” (in the projection system) and (2) the associated “ *optional ” word. the “FM” box from the projection system block in auditorium 2. The entire lower half of SPB2 in auditorium 2 eliminates “FM” and “Plain Text”, and shows only “LD”. The partitions have been removed, making the lower half one long box that says “LD”.

The Image Media Block can also be implemented as a component within the projection system. This provides the option of not requiring Link Encryption. In this configuration, the Image Media Block may use a push or pull method to process essence data from storage, as shown in Figure 12.

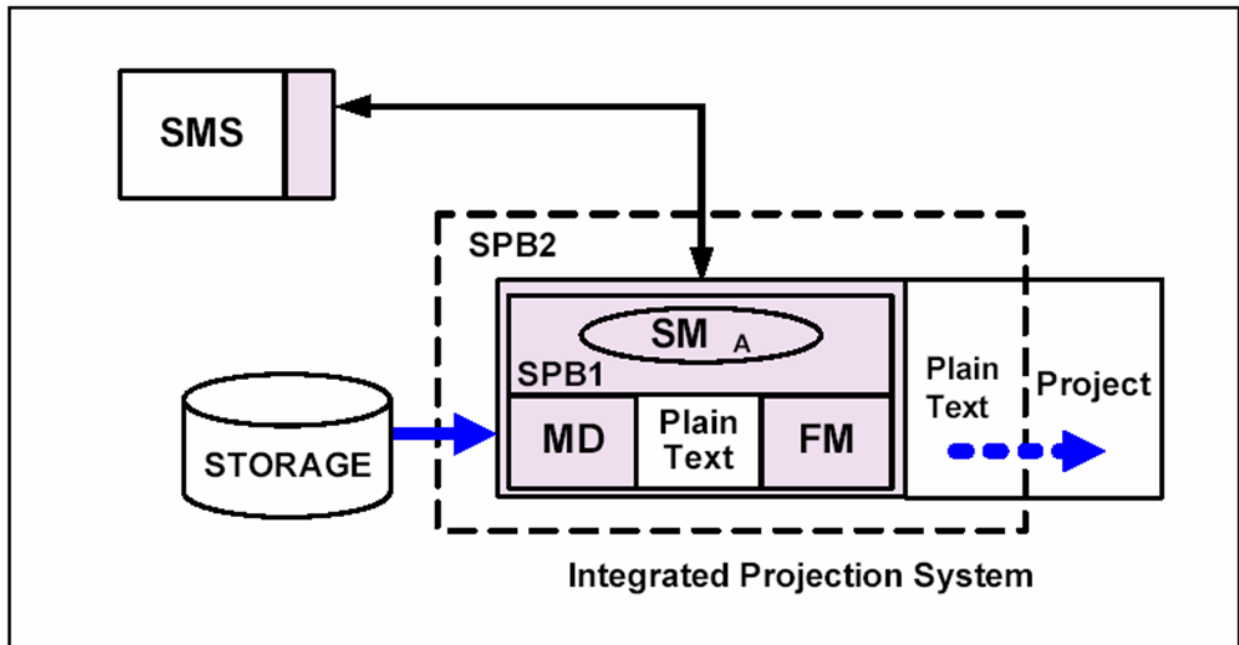

Figure 12: Media Block in Projector Configuration

In addition to the two single Image Media Block (IMB), single projector configurations shown above, this specification provides for Multiple Media Block (MMB) configurations to support multiple projectors and/or the use of an Outboard Media Block (OMB) within the projection booth. See Chapter 9 “SECURITY” for details of MMB and OMB requirements and operation.

Note: Due to the dynamic nature of security technology, DCI reserves the right, at some future time, to update requirements and may require changes to Digital Cinema systems as situations warrant.

7.5.4.2. Media Block Functional Requirements

7.5.4.2.1. Synchronization

The Media Block is the device that converts, in real time, the packaged content data from storage into data for playback to downstream devices. *The one or more Media Block(s) of the projection booth are required to playback the image, audio and other timed dependent content in a manner that presents a synchronized performance to the audience. Synchronization requirements are as follows:*

- *Synchronization of audio and on-screen text to image shall be frame accurate.*
- *Synchronization of audio objects shall be accurate to within 10 microseconds (sample accuracy at 96K).*
- *The synchronization signal shall include information that represents the current position within the show timeline and shall be accurate to within 10 microseconds.*

-
- “Locate and play” shall be supported.
 - The synchronization signal shall be defined separately from any essence it may be asked to synchronize, and able to sync multiple media blocks regardless of the essence they are handling.
 - The sync signal shall be defined independently of an interface or transport mechanism.

7.5.4.2.2. Security Functions

The main function of athe Media Block is to provide a secure environment within which to perform content essence decryption. *In support of this,*~~the Media Blocks~~ shall contain athe Security Manager, media decryptor(s)~~image, audio and subtitle processing~~ and ~~the~~(as applicable) associated forensic markers. Link Encryption shall be applied to image essence if the associated Media Block is not contained within the projection system.

All Media Blocks are required to provide logging functions per the requirements of Section 9.4.6.3.1 Logging Requirements.